



NEW FALL PROTECTION EQUIPMENT

KEEPING YOU SAFE FROM ONE LEVEL TO THE NEXT

AUSTRALIAN LIFTING CENTRE PTY LTD

1300 100 120

www.austlift.com.au

Fall Protection Equipment

Austlift Height Safety	195
Regular Inspections and Servicing	198
Removal of Equipment from Service	199
Terminology	199
Hierarchy of Control	200
Calculating Fall Clearance	201
Height Safety Applications	203
Understand Your Work Application	207
Strength Requirement for Anchorages	209
Anchor Points Information	209
Products Selection Guide	210
Harness Inspection	214
Harness Instruction	215
Trauma Strap Connection and Instruction	217
Harnesses and Belts	219
Lanyards	237
Inertia Reels	249
Confined Space Entry	255
Height Safety Kits	261
Anchorages	267
Hooks and Connectors	271
Temporary Life Line	274





Austlift Height Safety Range

Vision

To be Australasia's first choice in the lifting and safety industry and provide top-quality lifting, rigging, lashing, material handling and height safety products which can be trusted in their application while keeping the workplace safe.

Mission

- Innovate and design unique patented products.
- Implement customised solutions and products required for the unique situations that can occur within the industry which may otherwise be problematic.
- Delivery of inventive and resourceful expertise by our professional, efficient customer service team.
- Provide exemplary service and efficient supply of all product lines.
- Be professional in everything we do.
- Provide 100% customer satisfaction.

Austlift is an Australian owned company that has been providing high-quality lifting, lashing, material handling, and transport for more than 25 years. Our products are designed to withstand the toughest operating conditions and our new Height safety work place safety solutions help keep you safe in the most dangerous environments.

Austlift is in the business of innovation. With a team of product specialists at our disposal and a commitment to improving our offering, we are always on the lookout for ergonomic, comfortable and safe product solutions for you.

Our ever-increasing safety products range is designed to help you prevent falls from heights. We have a range of products for your workplace, whether it's construction, mining or general industrial.

With an extensive selection of harnesses, lanyards, anchors, confined space kits, rescue equipment or our new tool safety range, we will have you covered.

We make this happen by ensuring that all of our products are manufactured to meet AS standards, EN standards or other applicable international standards and Australian Design Rules, as well as providing full traceability on all of our products.

With our vision and mission at the core of our beliefs, Austlift is working on ensuring that our distributors and end users of the product have the best user experience possible. In addition to content rich catalogues with rich technical data, information and specifications Austlift is providing a new access point that is designed to provide flexibility, faster access, search functionality and organisation. All this while maintaining an easy to navigate user interface across all devices (mobile, tablet, desktop)

To find the ideal product solution for your situation simply visit www.austlift.com.au/lifting



Fall Protection
Equipment

Height safety equipment requires regular inspections and servicing

ALL HEIGHT SAFETY GEAR MUST BE INSPECTED BY A COMPETENT PERSON ON A REGULAR BASIS AS REQUIRED BY THE AS/NZS 1891.4 STANDARD:		
ITEM	INSPECTION FREQUENCY (NOTE 1)	REFERENCE
Personal equipment including harnesses, lanyards, connectors, fall-arrest devices including common use devices	Inspection by a Height Safety Operator and/or Height Safety Equipment Inspector (Note 2) before and after each use.	Clause 9.2
Harnesses, lanyards, associated personnel equipment	6-monthly inspection by a Height Safety Equipment Inspector (Note 3).	Clause 9.3.2
Fall-arrest devices (external inspection only)	6-monthly inspection by a Height Safety Equipment Inspector (Note 3).	Clause 9.3.4(a)
Ropes and slings	6-monthly inspection by a Height Safety Equipment Inspector (Note 3).	Clause 9.7
Anchorage—drilled-in type or attached to timber frames	12-monthly inspection by a Height Safety Equipment Inspector (Note 3).	Clause 9.3.3
Anchorage—other types	Up to 5-yearly inspection if recommended by the manufacturer. 12 monthly inspection is recommended by Austlift.	Clause 9.3.3
Fall-arrest devices—full service	Up to 5-yearly service if recommended by the manufacturer. Austlift recommends: Type 1 - yearly, sealed type 2 and type 3 - 2 yearly, unsealed type 2 and type 3 - yearly.	Clause 9.3.4(b)
Horizontal and vertical lifelines: Steel rope or rail (Ladder Safety Systems)	Austlift recommends: 5-yearly inspection for systems installed by a Austlift accredited installer, all other systems - yearly.	Clause 9.3.5
Horizontal or vertical lifelines: Fibre rope, Webbing	6-monthly inspection by a Height Safety Equipment Inspector (Note 3).	Clauses 9.3.5 & 9.7
All items of personal and common use equipment	Inspection by a Height Safety Equipment Inspector on entry or re-entry into service.	Clause 9.4
All items which have been stressed as a result of a fall	Inspection by a Height Safety Equipment Inspector before further use (Note 3).	Clause 9.5
NOTES: 1. Manufacturer's or supplier's recommendations where provided, take precedence over the frequencies listed. Where used in harsh conditions, more frequent inspection may be required. 2. If the user or operator of the equipment is not competent to carry out this inspection it is to be undertaken by another person who is competent, see Clause 9.2. 3. All inspections other than those by the operator are to be documented.		

Equipment Maintenance

- Clean equipment regularly following the manufacturer's instructions
- Store in a cool, dry place out of direct sunlight
- Protect from sharp edges, abrasion, corrosive substances or other possible causes of damage
- Do not subject to excessive heat, humidity or moisture
- Do not store under strain or pressure

Removal of Equipment from Service

- Six monthly service and/or periodical inspection is due
- It has been involved in a fall
- Labels have been removed, are missing or illegible
- Excessive abrasive wear (furry or frayed surfaces) has occurred
- Broken fibres, tears, cuts, snags and splinters are present
- Weld burns are present
- Deterioration or stretching has occurred
- Loss of resilience, discolouration or visible damage is experienced
- Parts and mechanisms are not moving freely or are corroded
- There is reduction in cross-section of rope area or webbing
- There is excessive contamination not removed by approved cleaning methods
- It is more than 10 years old for AS/NZS certified products

Terminology

COMPETENT PERSON	A 'Competent Person' is defined under AS/ NZS1891.4 as "A person who has, through a combination of training, qualification and experience, acquired knowledge and skills enabling that person to perform a specified task".
HEIGHT SAFETY OPERATOR	A person who is able to perform harness based work at heights under the direct supervision of a height safety supervisor.
HEIGHT SAFETY EQUIPMENT INSPECTOR	A person who is competent in the skills needed to detect faults in height safety equipment and to determine remedial action.
HEIGHT SAFETY SUPERVISOR	A person who is competent in the skills needed to perform harness based work at heights, to supervise other operators including those at entry level and to participate in first response rescue.
FALL DISTANCE AND WORKING SLACK	There is no such thing as a safe fall distance. This is regardless of the situation you are in or the equipment you are using. The further you fall, the faster you accelerate and the higher the total force required to be absorbed when you suddenly stop.
SECONDARY SYSTEM	Austlift promotes the use of primary and secondary "back-up" systems in both fall arrest and twin rope access situations. Consider your specific requirements when reviewing equipment needs and safety working procedures.

Fall Protection Equipment

Hierarchy of Control

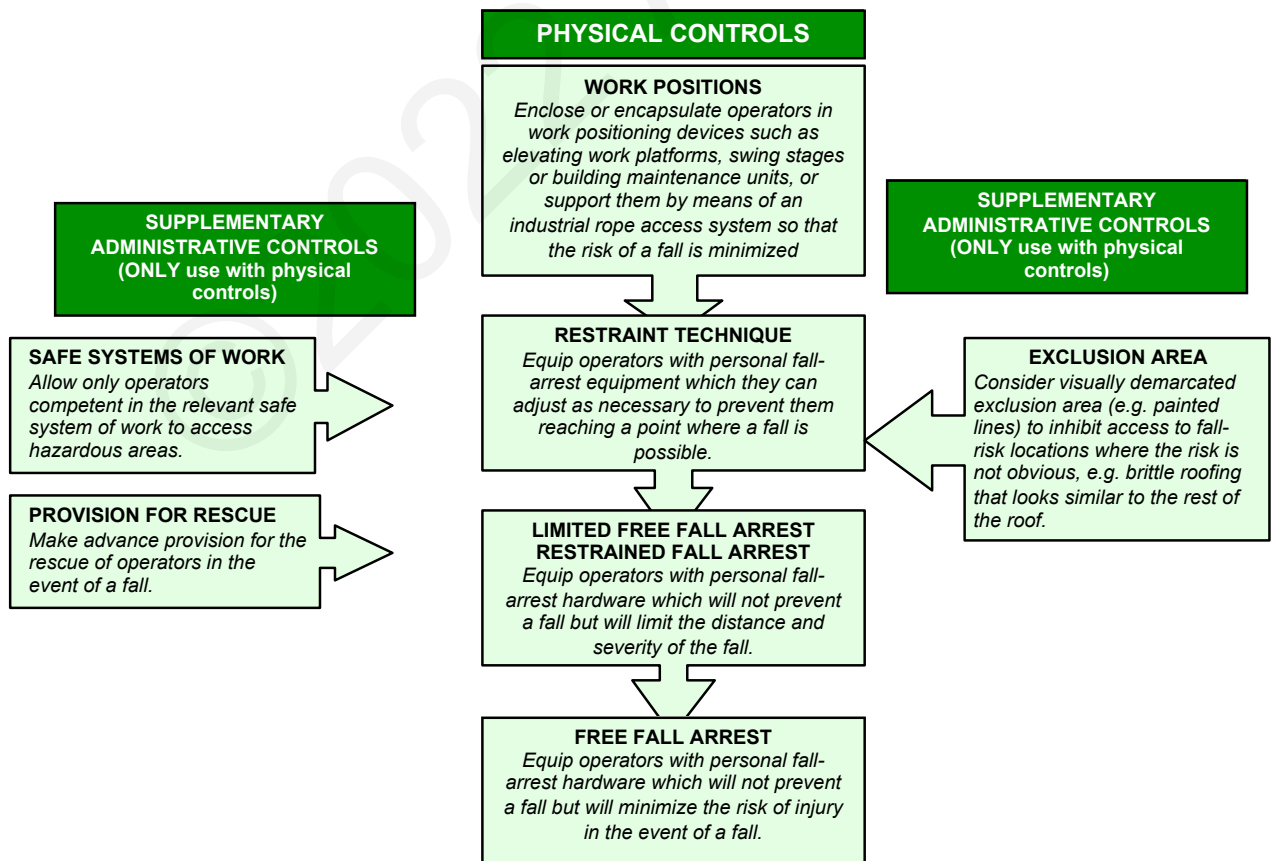
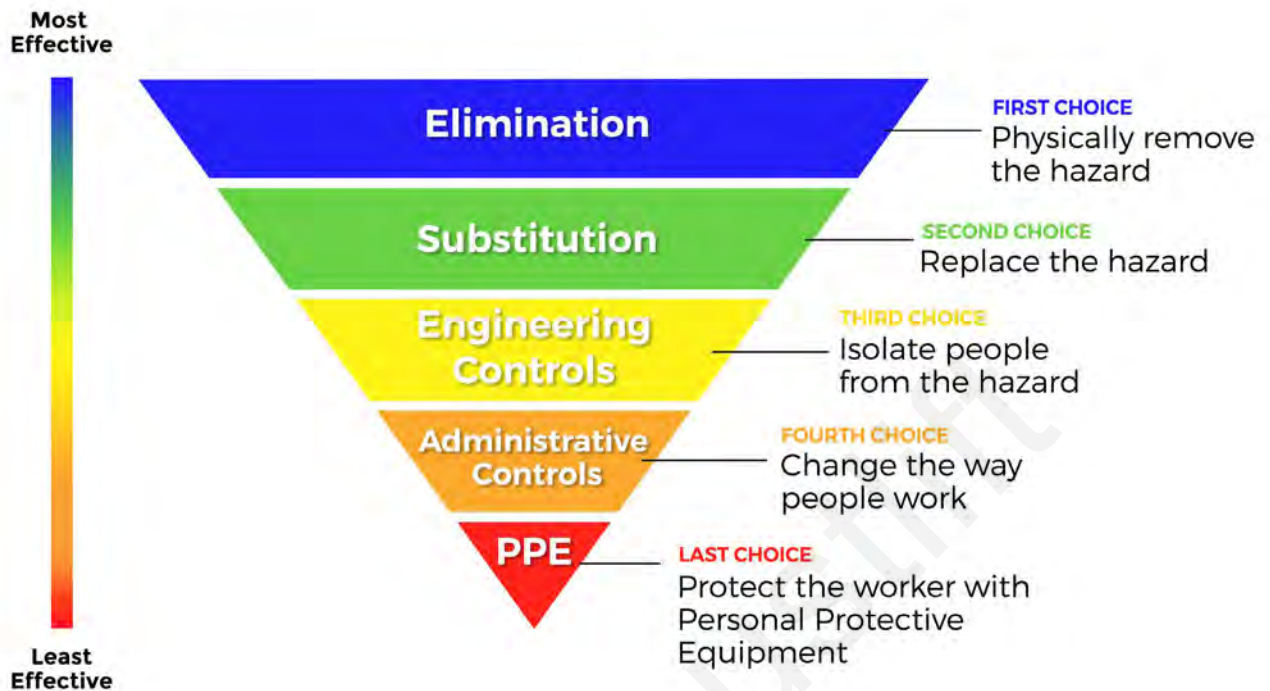

Calculating Fall Clearance

SHOCK ABSORBING LANYARD

$$RD = FFD + DD + C$$

RD = REQUIRED DISTANCE

Working Surface to Nearest Obstruction

FFD = FREE FALL DISTANCE

2.0M Maximum allowed

DD = ENERGY ABSORBER DECELERATION DISTANCE

+ D-RING SLIDE AND HARNESS STRETCH

When using a Austlift CORE lanyard (1.75m for users up to 120kg) or PRIME lanyard (1.95m for users up to 140kg) + D-ring Slide and Harness Stretch (0.25m)

C = CLEARANCE TO OBSTRUCTION DURING FALL ARREST

(1.0m minimum safety factor required)

AS PER AS/NZS 1891.4
DD can be estimated
based upon to reduce RD

FFD	EXTENSION
600 mm	300mm
1000mm	500mm
1500mm	600mm
2000mm	900mm

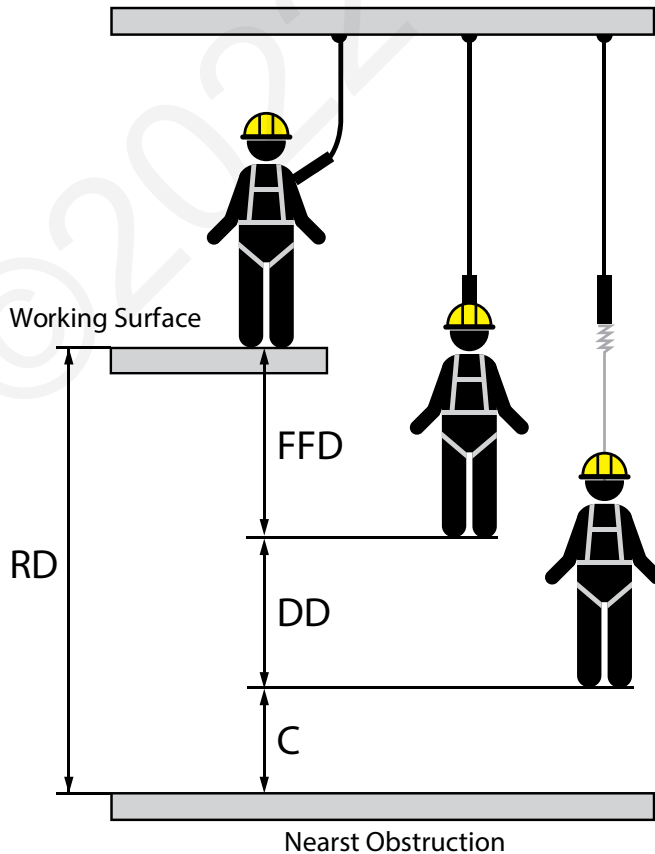

SELF RETRACTING LIFELINE

$$RD = FFD + DD + C$$

RD = REQUIRED DISTANCT

Required Distance Below Working Surface to Nearest Obstruction

DD = FREE FALL, LOCK OFF AND DECELERATION + D-RING SLIDE AND HARNESS STRETCH

Free Fall, Lock Off and Deceleration (1.4m Max.) + D-ring Slide and Harness Stretch (0.25m)

C = CLEARANCE

Clearance to Obstruction During Fall Arrest
(1.0m minimum safety factor required)

AS PER AS/NZS 1891.4, DD CAN BE ESTIMATED AT 700MM. 250MM MUST BE ADDED FOR D-RING SLIDE.

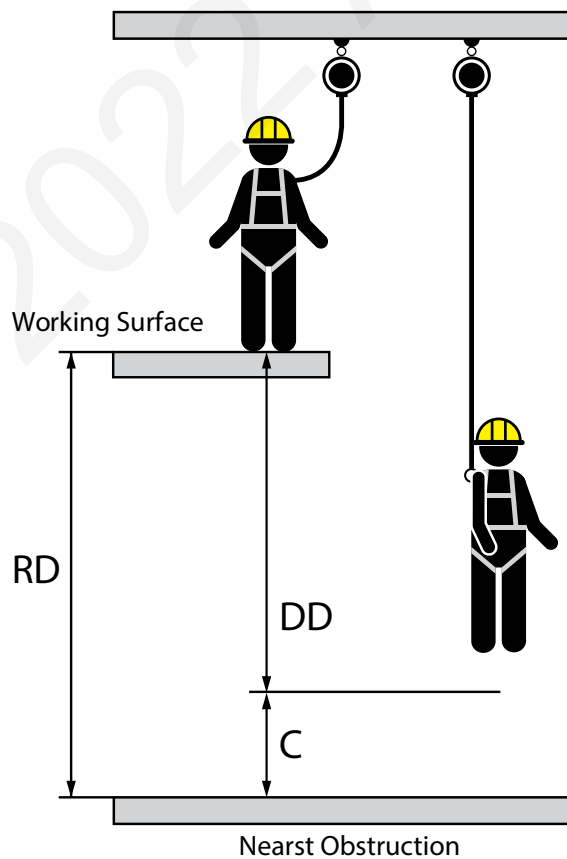

Height Safety Applications

FREE FALL ARREST

SYSTEM DESCRIPTION

A Fall Arrest System is one that is designed to stop the free fall of a user and limit the maximum arresting forces imposed on the user to 6kN or less. A Free Fall is described by the Standard AS/ NZS1891.1 as; a fall or the arrest of a fall where the fall distance before the fall-arrest system begins to take any loading, is in excess of 600mm either vertically or on a slope which it is not possible to walk without the assistance of a handrail or hand line.

REQUIREMENTS

1. Full-body harness Lanyard or fall-arrest device which will limit free fall to 2 m max.
2. 15 kN ultimate strength anchorage or equivalent horizontal lifeline or rail.

TYPICAL APPLICATION

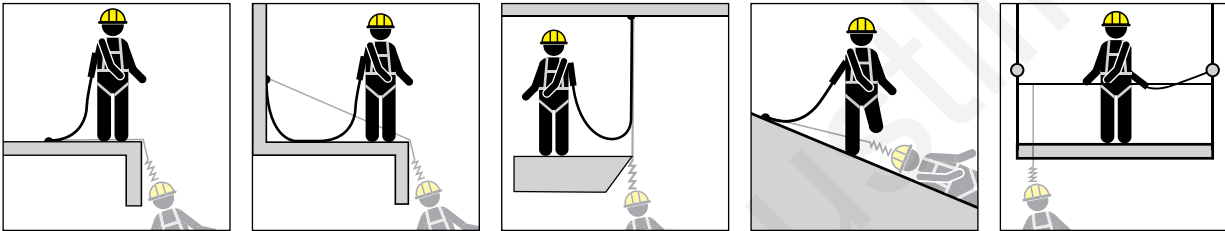

LIMITED FREE FALL

SYSTEM DESCRIPTION

A combination of anchorage placement and lanyard length which will permit only a limited free fall (< 600 mm).

REQUIREMENTS

1. Full-body harness. Lanyard or fall-arrest device that will limit free-fall to 600 mm max.
2. 12 kN ultimate strength anchorage or equivalent horizontal lifeline or rail.

TYPICAL APPLICATION

Any situation where the use of either a short lanyard or a fall-arrest device (or both where applicable) will limit any free fall to 600 mm. May also be applicable to rope access systems, see AS/NZS 4488.2.

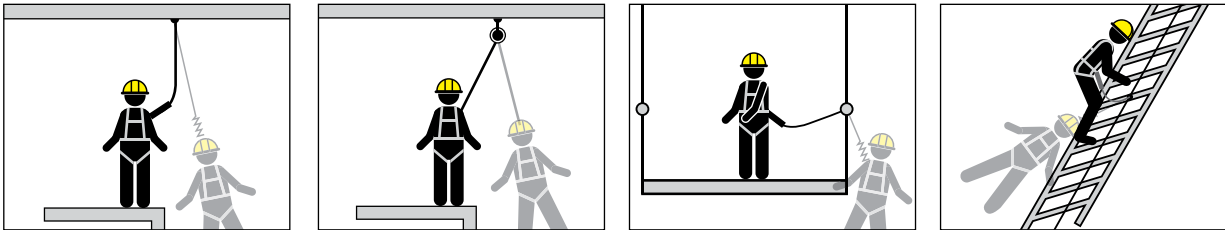

RESTRAINT TECHNIQUE

SYSTEM DESCRIPTION

A combination of anchorage placement and lanyard length adjustment which will not physically permit the operator to reach a fall risk position unless the lanyard is incorrectly adjusted. Control on a person's movement by use of a fall-arrest system, which entails connection to an anchorage using an adjustable lanyard or other components that can be adjusted for length as necessary to physically prevent the person from reaching a position at which there is a risk of a free or limited free fall.

REQUIREMENTS

Where any possible fall will only be a limited free fall (<600 mm):

1. A lower-body harness
2. Anchorage with ultimate strength 15 kN.

All other cases:

1. A full-body harness
2. Anchorage with ultimate strength

TYPICAL APPLICATION

Any situation where access to the work can be achieved entirely on a working surface with secure footing and without exposure to a fall provided that the equipment is correctly adjusted.

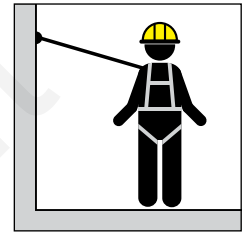

TOTAL RESTRAINT

SYSTEM DESCRIPTION

A system where no fall is possible.

REQUIREMENTS

Not specified in the AS/NZS 1891 Series of Standards.

TYPICAL APPLICATION

Total restraint is defined as the control on a person's movement by means of a connection to an anchorage in such a way that it will physically prevent the person from reaching any position at which there is risk of a fall, either over an edge, through a surface or due to a failed moveable platform.

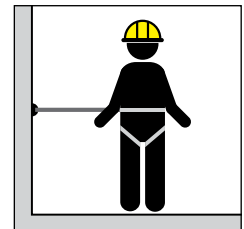

WORK POSITIONING (RESTRAINED FALL)

SYSTEM DESCRIPTION

A Work Positioning System is one that is designed to hold and sustain the user at a work location and limit the free fall to 600mm maximum.

A Restrained Fall is described by the Standard AS/NZS 1891.4 as; the use of equipment such as a harness and adjustable lanyard which can be adjusted by the user to maintain a restraint condition in different situations as the distance from anchorage to a potential fall zone varies. It assumes that the level of user training and competence is adequate to counter the additional risk factor.

REQUIREMENTS

Full-body or lower-body harness and pole strap.

TYPICAL APPLICATION

Working on a pole where no more than 600mm maximum free fall is possible.

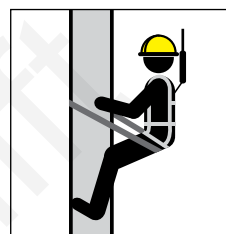

SUSPENSION

SYSTEM DESCRIPTION

A Suspension System is designed to suspend and support the user while being transported (raised up or down) vertically and does not allow free fall. After a fall in a full body harness, the user may be suspended in a position that they can not recover themselves from, like over the edge of a platform. The rescuers will setup the rescue kit, attach the rescue system to the victim and detach them from their fall arrest device, raise or lower them to safety.

REQUIREMENTS

Full-body harness with two fall arrest attachment points, a primary attachment for suspension along with a secondary backup system. The use of a podium seat may be required for longer suspension work. Front attachment points on the harness are best for suspension. Suitable anchor points rated to 12kN or a tripod or davit system. 15kN anchor point will be required if a fall greater than 600mm may occur.

TYPICAL APPLICATION

Confined space work where you may be required to lowered or lifted out of a tank.



RESCUE

SYSTEM DESCRIPTION

A Rescue system is designed to raise or lower a user to safety in the event of an emergency. No free fall should be possible.

REQUIREMENTS

A full body harness, a suitable anchorage point to ensure the rescuer is safe. A rescue system that can either raise or lower the rescued user to safety. Suitable anchor points rated to 15kN

TYPICAL APPLICATION

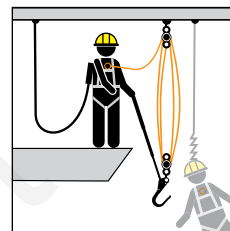

TWIN ROPE ACCESS

SYSTEM DESCRIPTION

The practice of twin rope access requires that free fall should be eliminated through the implementation of specific work procedures, defined in competency based training. Twin rope access does not normally require the use of a shock absorbing lanyard, as the worker must ensure that all working slack is removed from rope lines whilst in suspension, ascending and descending, to avoid the possibility of a free-fall. This systems does however promote the use of cows tails and other devices such as dynamic rope to achieve a reduction in force during a fall.

REQUIREMENTS



A full body rescue suspension harness with multiple front fall rated attachment points, a primary descent device and a secondary backup fall arrester. Two separate kernmantle rope lines. This is a very specialised type of work and can require all different types of rope grab devices, descenders, ascenders etc. Suitable anchors rated to 12kN

TYPICAL APPLICATION

Window washing of the side of a highrise building

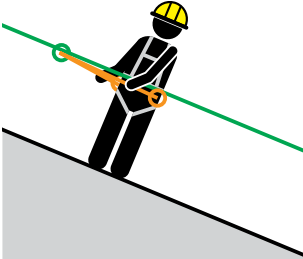

UNDERSTAND YOUR WORK APPLICATION WITH PERSONAL PROTECTION EQUIPMENT

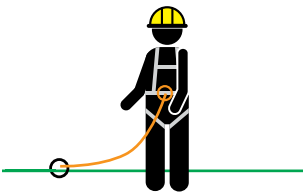
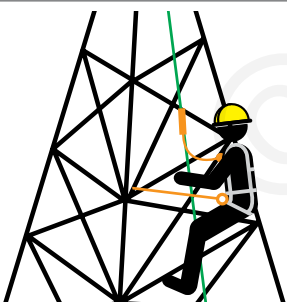
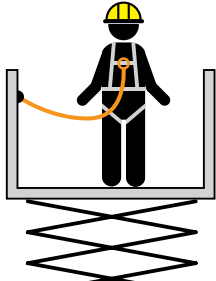
Work Application	Before working at heights a full risk assessment and work method shall be completed to understand the proper use and limitations of PPE equipment.	PPE Products
		Harness
		Connection
		Anchor
BE AWARE OF THESE SAFETY POINTS		
	<p>ROOF WORK</p> <ul style="list-style-type: none"> • Ensure anchor points are correctly installed, fitted and are suitability rated and certified. • When using rope & rope grabs always ensure the rope line is taught from both anchor points. • Shock absorber connection shall be between harness frontal or rear attachments and rope grab via karabiner. • Make sure you utilize rear dee or frontal dees of your harness while working at all times. • If there are no anchor points present you should use an appropriate anchorage system to a suitable structure ensuring the structure can support a fall arrest situation. 	<p>Full body harness with frontal & rear attachments.</p> <p>Approved rope & rope adjuster with shock absorber pack.</p> <p>Temporary metal roof anchor or Anchorage sling.</p>
	<p>LADDER WORK</p> <ul style="list-style-type: none"> • For fixed ladder safety lines ensure it has been certified, maintained and operating satisfactory before use. • With mobile ladders ensure the ladder has been secured properly with certified ladder brackets. • Use certified anchor systems such as anchor strap, fixed anchor point or temporary anchor point. • Ensure safety rope line is correctly tied off and rope grab is fixed to frontal connection points of harness with karabiner. • Always use a full body harness and twin lanyard with shock absorber for ladder work. 	<p>Full body harness with frontal & rear attachments.</p> <p>Twin lanyard with shock absorber. Approved rope & rope adjuster.</p> <p>Anchorage sling, certified ladder.</p>
	<p>CONSTRUCTION & MAINTENANCE</p> <ul style="list-style-type: none"> • Ensure anchor points are correctly installed, fitted and are suitability rated and certified. • When using rope & rope grabs, always ensure the rope line is taut from the anchor points. • Ensure fall arrest systems have been regularly serviced and in good working condition. • Use single lanyard or twin elasticised lanyards with shock absorber • Make sure you utilize rear dee or frontal dees of your harness whilst working at heights. • With static lines ensure the system is certified and in good condition and working order. 	<p>Full body harness with frontal & rear attachments.</p> <p>Single or Twin lanyard with shock absorber. Approved Rope & rope adjuster.</p> <p>Suitable Inertia reels, Anchorage sling, suitable anchor.</p>
	<p>TOWER WORK</p> <ul style="list-style-type: none"> • Ensure anchor points are correctly installed, fitted and are rated and certified. • When using rope & rope grabs always ensure the rope line is taught from the anchor points. • Ensure fall arrest equipment has been regularly serviced and in good working condition. • Make sure you utilize rear dee of your harness with twin lanyard and belay loops with pole strap of your harness whilst working at heights. • With permanent ladder systems ensure the structure is certified and in good condition and working order. 	<p>Full body tower workers harness.</p> <p>Twin lanyard with shock absorber, approved rope adjuster.</p> <p>Adjustable pole straps anchorage sling.</p>
	<p>ELEVATED WORK PLATFORMS</p> <ul style="list-style-type: none"> • Ensure anchor points and elevated work platforms are correctly installed, fitted and are suitability rated and certified. • Ensure fall arrest equipment has been regularly inspected, serviced and in good working condition. • Make sure you utilize rear dee or side dees of your harness with either webbing, adjustable or elastic single lanyard of your harness whilst working at heights. 	<p>Full body harness with frontal & rear attachments.</p> <p>Single lanyard with shock absorber.</p>

Fall Protection Equipment

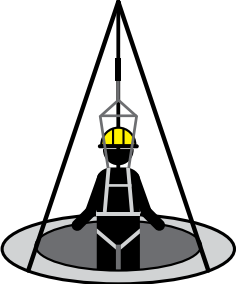
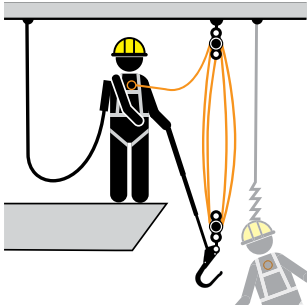
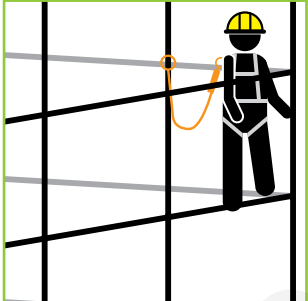
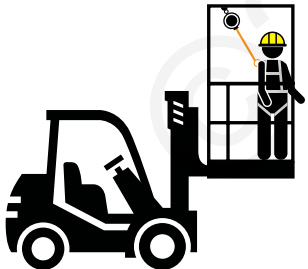
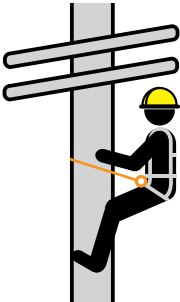
UNDERSTAND YOUR WORK APPLICATION WITH PERSONAL PROTECTION EQUIPMENT		
Work Application	Before working at heights a full risk assessment and work method shall be completed to understand the proper use and limitations of PPE equipment.	PPE Products
		Harness
		Connection
		Anchor
BE AWARE OF THESE SAFETY POINTS		
	<p>CONFINED SPACE & RESCUE</p> <ul style="list-style-type: none"> • Ensure confined space and/or rescue equipment is being regularly inspected, serviced and in good working condition • Ensure tripod or davit system are correctly installed, fitted and are suitability rated and certified. • Prior to use, inspect inertia reel and rescue winch to ensure they are in good working condition. • Make sure you utilize the rescue loops for rescue operation of your harness and rear dee in a confined space situation. • With spreader bar the arm straps should be utilized. 	<p>Full body harness with rear attachment and shoulder confined space loops.</p> <p>Rescue winch devise. Confined space spreader bar.</p> <p>Tripod or Davit arm.</p>
	<p>RESCUE</p> <ul style="list-style-type: none"> • Ensure you have a suitable rescue plan before commencing work at heights. • Select a rescue kit suitable for the environment the rescue may be required for. (Length, do you need to lift or lower) • Ensure fall arrest equipment has been regularly inspected, serviced and in good working condition. • Make sure you utilise front dees of a harness to attach the rescue recovery system to to give you full control and view of rescue. 	<p>Full body harness with frontal and rear attachment point</p> <p>Shock absorbing lanyard, rescue kits and a rescue pole</p> <p>Suitable anchor point</p>
	<p>SCAFFOLDING</p> <ul style="list-style-type: none"> • Ensure when connecting to the structure, the anchor point (Scaffold structure) could support a 15 kN load • Ensure fall arrest equipment has been regularly serviced and in good working condition. • Make sure you utilise rear dee of your harness with twin lanyard and scaffold hooks whilst working at heights. • Twin retractable units attached to the back dee of the harness may be more suitable in lower scaffolding builds due to the reduced fall factor. 	<p>Full body harness with frontal and rear attachment point</p> <p>Twin shock absorbing lanyard or twin retractable blocks with scaffold hooks</p>
	<p>WAREHOUSE</p> <ul style="list-style-type: none"> • Ensure anchor points on elevation cage are correctly installed, fitted and are suitability rated and certified. • Ensure fall arrest equipment has been regularly inspected, serviced and in good working condition. • Make sure you utilise rear dee with retractable webbing lanyard to reduce the fall factor to the shortest possible length while giving you maximum range of movement. 	<p>Full body harness with frontal and rear attachment point</p> <p>Retractable block</p> <p>Accessible anchor point or anchor sling</p>
	<p>UTILITIES</p> <ul style="list-style-type: none"> • Ensure when connecting to the cross arm of the pole it is able to sustain the force of a limited fall (12kN). • Ensure fall arrest equipment has been regularly serviced and in good working condition. • Make sure you utilise rear dee of your harness with shock absorbing lanyard and pole strap attachments with pole strap on your harness whilst working at heights. • Always ensure you are connected, the use of two pole straps will allow for the transition from below to above the cross arm beam while maintaining one connection at all times. 	<p>Full body harness with rear attachment point</p> <p>Pole strap attachment points, pole strap and secondary fall arrest lanyard</p>

Fall protection Equipment

Strength Requirement for Anchorages

PURPOSE OF ANCHORAGES	MINIMUM ULTIMATE STRENGTH IN DIRECTION OF LOADING (KILO NEWTONS)
Free fall-arrest-One person	15 kN
Free fall-arrest-Two persons attached to same anchor.	21 kN
Limited free fall-arrest (Including rope access anchorages)	12 kN
Restraint technique	15 kN for free fall risk 12 kN for limited free fall risk
Horizontal life lines	Minimum ultimate strength in Direction of loading (kilo newtons)
End Anchorages (See manufactures recommendations)	Greater than 15 kN single person Greater than 21 kN multiple persons
Intermediate anchorages -Diversion less than 15°	12 kN
NOTE	
As far as practicable all single point one-person anchorages should meet the 15kN requirements regardless of primary purpose.	
'Ultimate strength' means that the anchorage may yield at the stated load but must not fail.	

Anchor Points Information

- Ensure the anchor points on a building or structure used by the operator are certified by an engineer, unless it is clear to a height safety supervisor the anchorage system is structurally sound also signage with anchor information shall be provided.
- Use table provided to ensure the anchorage is capable of sustaining the ultimate load for one person to use when loaded in the direction of the lanyard, anchorage line, or restraint line during fall arrest.
- For two people utilizing one anchor point the load requirement for the anchorage shall be increased to a minimum of 21kN and no more than two people shall use a single anchor at any time.
- Be aware of free fall situation using anchorages. This applies to a free fall-arrest where fall situation >600mm and for limited free fall where fall situation is < 600mm and you should not climb above an anchor point.
- From the anchor point observe any lower obstruction in a fall situation that the operator may strike into eg; machinery, open window etc.
- If an anchor looks damaged it should be recertified by a competent person before using.
- If in doubt about anchorages check with the manufacture and/or refer to AS/ NZS 5532:2017



WARNING
Only authorized personnel can install and certify roofing anchors.

Fall Protection Equipment

HARNESSELECTION GUIDE															
SERIES	NAME	CODE	DORSAL D-RING	FRONT D-RING	LATERAL D-RING	TOTAL RESTRAINT D-RING	LATERAL O-RING	EXTENSION STRAP	CONNECTION BUCKLE	ADDITIONAL LOOPS			SEAT STRAP	TRAUMA STRAP	PAGE
										SHOULDER	CHEST	TOOL			
CORE	Tradesman Harness	915001	Steel Dorsal D-Ring	/	/	/	/	/	Steel Combination Buckle	/	Frontal Belay Loops	/	Thigh Seat Connect Strap	/	214
	Tradesman Plus Harness	915002	Steel Dorsal D-Ring	/	/	/	/	Extension Lanyard	Steel Combination Buckle	/	Frontal Belay Loops	/	Thigh Seat Connect Strap	/	215
	Cross Over Harness	915004	Steel Dorsal D-Ring	Steel Front D-Ring	/	/	/	/	Steel Combination Buckle	/	/	/	Thigh Seat Connect Strap	/	216
	Riggers Harness	915003	Steel Dorsal D-Ring	Steel Front D-Ring	/	/	/	/	Steel Quick Release Buckle	Shoulder Loops	/	/	Thigh Seat Connect Strap	Trauma Strap Fitted	218
PRIME	Positioning Harness	915005	Steel Dorsal D-Ring	Steel Front D-Ring	Steel Lateral D-Rings	/	/	/	Steel Quick Release Buckle	/	/	/	Thigh Seat Connect Strap	Trauma Strap Fitted	220
	Comfort Harness	915008	Aluminium Dorsal D-Ring	Aluminium Front D-Ring	/	/	/	/	Steel Quick Release Buckle	Shoulder Loops	/	/	Thigh Seat Connect Strap	Trauma Strap Fitted	219
	Comfort Restraint Harness	916009	Aluminium Dorsal D-Ring	Aluminium Front D-Ring	/	Aluminium Total Restraint D-Ring	/	/	Steel Quick Release Buckle	Shoulder Loops	/	/	Seat Configuration Strap	Trauma Strap Fitted	225
	Tower Harness	915010	Aluminium Dorsal D-Ring	/	Aluminium Lateral D-Rings	/	Steel Lateral O-Rings	/	Aluminium Combination Buckle	Shoulder Loops	Frontal Belay Loops	Tool Holding Loops	Seat Configuration Strap	/	224
	Hot Works Harness	915016	Steel Dorsal D-Ring	/	/	/	/	/	Steel Quick Release Buckle	Shoulder Loops	Frontal Belay Loops	/	Thigh Seat Connect Strap	Trauma Strap Fitted	221
	Hot Works Plus Harness	915017	Stainless Steel Dorsal D-Ring	/	/	/	/	/	Stainless Steel Combination Buckle	Shoulder Loops	Frontal Belay Loops	/	Thigh Seat Connect Strap	/	222
	Water works Harness	915018	Stainless Steel Dorsal D-Ring	/	/	/	/	/	Stainless Steel Combination Buckle	Shoulder Loops	Frontal Belay Loops	/	Thigh Seat Connect Strap	Trauma Strap Fitted	223
	Elect Tower Harness	915011	Webbing Dorsal D-Ring	/	/	/	/	Steel Lateral O-Rings	Plastic & Steel Quick Release Buckle	/	/	Tool Holding Loops	Seat Configuration Strap	/	226
	All Purpose Harness	915012	Aluminium Dorsal D-Ring	Aluminium Front D-Ring	Aluminium Lateral D-Rings	/	/	/	Aluminium Quick Release Buckle	Shoulder Loops	/	Tool Holding Loops	Seat Configuration Strap	/	227
	Tower Harness	915013	Aluminium Dorsal D-Ring	Aluminium Front D-Ring	/	/	Aluminium Lateral O-Rings	/	Aluminium Quick Release Buckle	Shoulder Loops	/	/	Seat Configuration Strap	/	228
Riggers Harness	915014	Aluminium Dorsal D-Ring	Aluminium Front D-Ring	Aluminium Lateral D-Rings	Aluminium Total Restraint D-Ring	/	/	Aluminium Quick Release Buckle	Shoulder Loops	/	Tool Holding Loops	Seat Configuration Strap	/	229	
			MaxiPro												

LANYARD SELECTION GUIDE									
SERIES	NAME	CODE	LENGTH	MATERIAL	TYPE		ONE SIDE	OTHER SIDE	PAGE
CORE	Single Webbing Lanyard	916100	1.8M	Polyester	Flat Webbing	Single	Steel Double-Action Snap Hook	Steel Double-Action Snap Hook	232
	Single Elasticated Webbing Lanyard	916101	1.4-1.6M	Polyester	Elasticated Webbing	Single	Steel Double-Action Snap Hook	Steel Double-Action Snap Hook	232
	Single Webbing Lanyard	916111	1.8M	Polyester	Flat Webbing	Single	Steel Double-Action Snap Hook	Steel Scaffold Hook	232
	Single Elasticated Webbing Lanyard	916112	1.4-1.6M	Polyester	Elasticated Webbing	Single	Steel Triple-Action Hook	Steel Scaffold Hook	232
	Double Webbing Lanyard	916122	2M	Polyester	Flat Webbing	Double	Steel Double-Action Snap Hook	Steel Scaffold Hook	233
	Double Adjustable Webbing Lanyard	916126	2M	Polyester	Flat Webbing	Double	Steel Double-Action Snap Hook	Steel Scaffold Hook	233
	Double Elasticated Webbing Lanyard	916123	1.4-1.6M	Polyester	Elasticated Webbing	Double	Steel Triple-Action Hook	Steel Scaffold Hook	234
	Single Webbing Lanyard	916105	1.8M	Polyester	Flat Webbing	Single	Steel Triple-Action Hook	Steel Triple-Action Hook	232
	Single Elasticated Webbing Lanyard	916106	1.4-1.6M	Polyester	Elasticated Webbing	Single	Steel Triple-Action Hook	Steel Triple-Action Hook	232
	Single Adjustable Webbing Lanyard	916110	1.8M	Polyester	Flat Webbing	Single	Steel Triple-Action Hook	Steel Triple-Action Hook	233
PRIME	Double Webbing Lanyard	916120	2M	Polyester	Flat Webbing	Double	Steel Triple-Action Hook	Steel Triple-Action Hook	234
	Double Elasticated Webbing Lanyard	916121	1.4-1.6M	Polyester	Elasticated Webbing	Double	Steel Triple-Action Hook	Steel Triple-Action Hook	234
	Single Sharp Edge Rope Lanyard	916201	1.8M	Sharp Edge Resistant Kermantle Rope		Single	Steel Double-Action Snap Hook	Steel Double-Action Snap Hook	235
	Single Sharp Edge Rope Lanyard	916204	1.8M	Sharp Edge Resistant Kermantle Rope		Single	Steel Triple-Action Hook	Steel Triple-Action Hook	235
	Single Sharp Edge Adjustable Rope Lanyard	916228	1.8M	Sharp Edge Resistant Kermantle Rope		Single	Steel Triple-Action Hook	Steel Triple-Action Hook	235
	Single Sharp Edge Adjustable Rope Lanyard	916231	1.8M	Sharp Edge Resistant Kermantle Rope		Single	Steel Triple-Action Hook	Steel Scaffold Hook	235
	Double Sharp Edge Rope Lanyard	916212	2M	Sharp Edge Resistant Kermantle Rope		Double	Steel Double-Action Snap Hook	Steel Scaffold Hook	236
	Double Sharp Edge Rope Lanyard	916209	2M	Sharp Edge Resistant Kermantle Rope		Double	Steel Triple-Action Hook	Steel Triple-Action Hook	236
	Double Sharp Edge Adjustable Rope Lanyard	916229	2M	Sharp Edge Resistant Kermantle Rope		Double	Steel Triple-Action Hook	Steel Triple-Action Hook	236
	Double Sharp Edge Adjustable Rope Lanyard	916230	2M	Sharp Edge Resistant Kermantle Rope		Double	Aluminum Alloy Triple-Action Hook	Steel Scaffold Hook	236
SHARP EDGE	Double Sharp Edge Adjustable Rope Lanyard	916232	2M	Sharp Edge Resistant Kermantle Rope		Double	Steel Triple-Action Hook	Steel Scaffold Hook	237
	Double Sharp Edge Adjustable Rope Lanyard	916233	2M	Sharp Edge Resistant Kermantle Rope		Double	Aluminum Alloy Triple-Action Hook	Aluminum Alloy Scaffold Hook	237
	Double Sharp Edge Adjustable Rope Lanyard	916234	2M	Sharp Edge Resistant Kermantle Rope		Double	Aluminum Alloy Triple-Action Hook	Aluminum Alloy Triple-Action Hook	237

LANYARD SELECTION GUIDE									
SERIES	NAME	CODE	LENGTH	MATERIAL	TYPE		ONE SIDE	OTHER SIDE	PAGE
					FLAT WEBBING	FLAT WEBBING			
Hot Works	Single Hot Works Webbing Lanyard	916140	1.8M	Flame Retardant Aramid Webbing	Flat Webbing	Single	Steel Double-Action Snap Hook	Steel Double-Action Snap Hook	238
	Single Hot Works Webbing Lanyard	916141	1.4-1.6M		Flat Webbing	Single	Steel Double-Action Snap Hook	Steel Scaffold Hook	238
	Double Hot Works Webbing Lanyard	916142	2M		Flat Webbing	Double	Steel Double-Action Snap Hook	Steel Scaffold Hook	238
ADJUSTABLE	5M Steel Adjustable Lanyard	915843	5M	Sharp Edge Resistant Kermantle Rope		Single	Steel Quarter Turn Locking Karabiner with Safety Pin	Steel Rope Grab with Steel Triple-Action Karabiner with Safety Pin	239
	15M Steel Adjustable Lanyard	915840	15M	Sharp Edge Resistant Kermantle Rope		Single	Steel Quarter Turn Locking Karabiner with Safety Pin	Steel Rope Grab with Steel Triple-Action Karabiner with Safety Pin	239
	20M Steel Adjustable Lanyard	915841	20M	Sharp Edge Resistant Kermantle Rope		Single	Steel Quarter Turn Locking Karabiner with Safety Pin	Steel Rope Grab with Steel Triple-Action Karabiner with Safety Pin	239
	25M Steel Adjustable Lanyard	915842	25M	Sharp Edge Resistant Kermantle Rope		Single	Steel Quarter Turn Locking Karabiner with Safety Pin	Steel Rope Grab with Steel Triple-Action Karabiner with Safety Pin	239
	15M Alloy Adjustable Lanyard	916315	15M	Sharp Edge Resistant Kermantle Rope		Single	Steel Quarter Turn Locking Karabiner with Safety Pin	Aluminium Alloy Rope Grab with Steel Triple-Action Karabiner with Safety Pin	240
	20M Alloy Adjustable Lanyard	916520	20M	Sharp Edge Resistant Kermantle Rope		Single	Steel Quarter Turn Locking Karabiner with Safety Pin	Aluminium Alloy Rope Grab with Steel Triple-Action Karabiner with Safety Pin	240
	30M Alloy Adjustable Lanyard	916330	30M	Sharp Edge Resistant Kermantle Rope		Single	Steel Quarter Turn Locking Karabiner with Safety Pin	Aluminium Alloy Rope Grab with Steel Triple-Action Karabiner with Safety Pin	240

INERTIA REEL BLOCK SELECTION GUIDE											
TYPE	CODE	LENGTH	MATERIAL	RATED	TOP	BOTTOM	SWIVEL	ENERGY ABSORBER	RETRIEVAL APPLICATION	SHARP EDGE	PAGE
915210	10M	Wire Rope	140kg	Steel Triple-Action Karabiner	Steel Triple-Action Swivel Hook	Swivel Eye Bolt	Energy Absorber	/	Sharp Edge	242	
915220	20M	Wire Rope	140kg	Steel Triple-Action Karabiner	Steel Triple-Action Swivel Hook	Swivel Eye Bolt	/	/	/	243	
915230	30M	Wire Rope	140kg	Steel Triple-Action Karabiner	Steel Triple-Action Swivel Hook	Swivel Eye Bolt	/	/	/	243	
Retrieval Rope	915320	20M	Wire Rope	140kg	Steel Triple-Action Karabiner	Steel Triple-Action Swivel Hook	Swivel Eye Bolt	/	Retrieval Application	/	246
	915321	30M	Wire Rope	140kg	Steel Triple-Action Karabiner	Steel Triple-Action Swivel Hook	Swivel Eye Bolt	/	Retrieval Application	/	247
Webbing	915303	3.5M	Webbing	140kg	Steel Triple-Action Karabiner	Steel Triple-Action Swivel Hook	Swivel Eye Bolt	/	/	/	244
	915302	2.5M	Webbing	140kg	Steel Triple-Action Karabiner	Steel Triple-Action Karabiner	/	Energy Absorber	/	/	244
	915342	2M	Webbing	Vert. 140kg/ Horz. 100kg	/	Steel Turn-locking hook	Swivel Eye Point	Energy Absorber	/	Sharp Edge	245
	915344	2M	Webbing	Vert. 140kg/ Horz. 100kg	/	Aluminium Rebar hook	Swivel Eye Point	Energy Absorber	/	Sharp Edge	245

Fall protection Equipment

Austlift Harness Size

Austlift Standard Harnesses are provided in size: M-XXL, suitable for users from 65kg to 120kg weight, and 1.54M -1.96M height. Weight under 65kg or over 120kg and Height over 1.96M also available upon request.



SIZE: S Available Upon Request

SIZE: M-XXL Standard Size

SIZE: XXL+ Available Upon Request

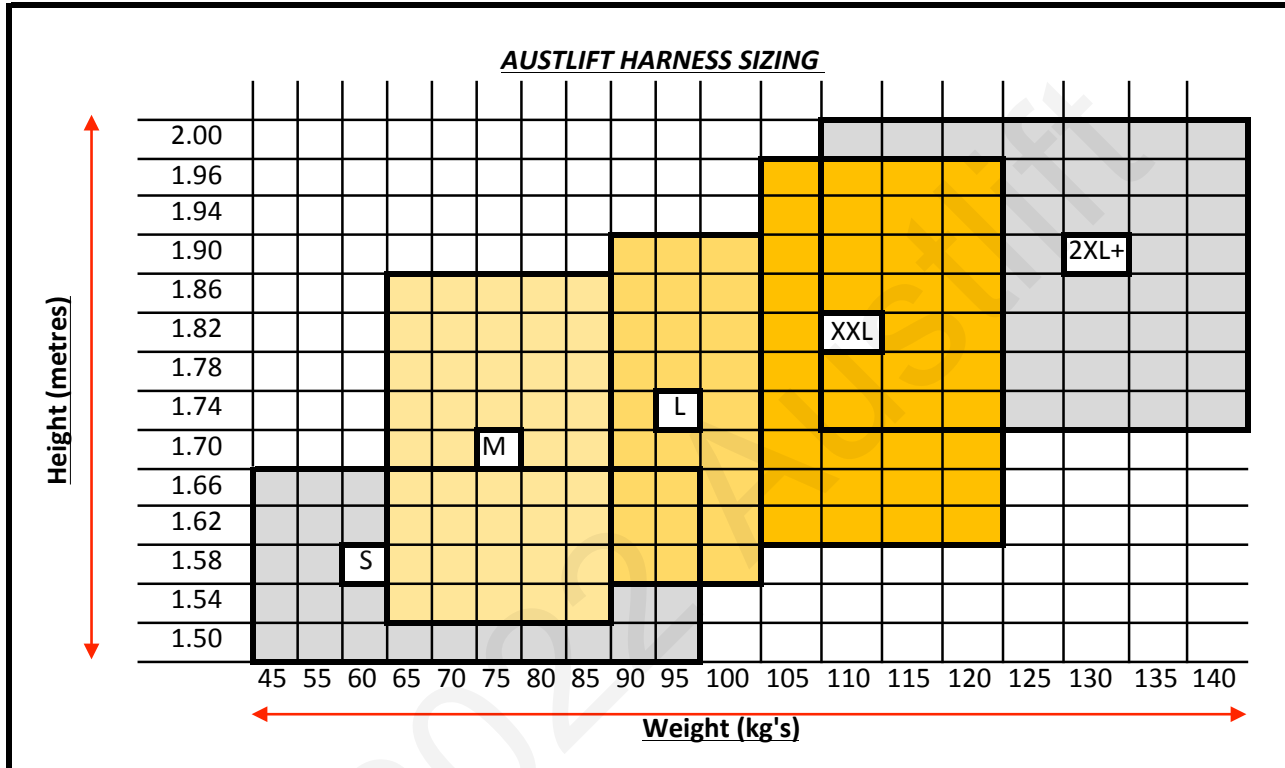

Quick Connect Buckles Instruction



STEP 1

Inspect the harness to ensure its fit for use. Locate the front of the harness and remove any twists or bunching in the webbing.



STEP 2

Slide the harness on like you would a jacket. Place harness over your shoulders,



STEP 3

Ensure the triangular back section and D-ring should sit between shoulder blades in the centre of your back.



STEP 4

Locate the front chest strap and align the tongue with the slot in the receptor buckle and insert.



STEP 5

Push together until hearing a distinct click and the "lock" mark appears in the window of lock indicator.



STEP 6

Adjust the strap until the harness fits firmly.



STEP 7

Repeat the process with both leg straps Adjust the strap until the harness fits firmly.



STEP 7

Make sure there are no twists in harnesses webbing and chest D-ring is located on the chest.



STEP 8

Once harness is fitted correctly get your work mate to check it over.

WARNING: Failing to fit or maintain harness properly may cause serious injury or death.

NOTICE: please note this instruction does not replace or remove the need for the end user of all safety products to undergo competence based training.

Fall Protection Equipment

2-3 Bar Buckles Instruction



STEP 1

Inspect the harness to ensure it is fit for use. Locate the dorsal D ring of the harness and align it in its correct orientation.

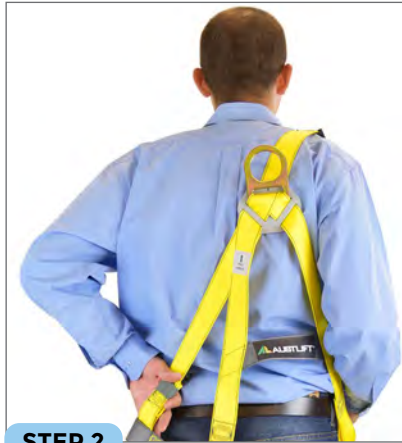

STEP 2

Take out any twists in the webbing. Slide the harness on like you would a jacket. Place harness over your shoulders.



STEP 3

Ensure the triangular back section and D-ring should sit between your shoulder blades in the centre of your back.



STEP 4

Bring the two buckles together, ensuring there are no twists in the webbing.



STEP 5

Turn the 3 bar buckle and push it through the 2 bar buckle.



STEP 6

Ensure both buckles lay flat against one another and tension the strap.



STEP 7

Fit leg straps ensuring the webbing is sitting flat against the legs. Always connect the left leg strap to the left leg buckle never cross them over.

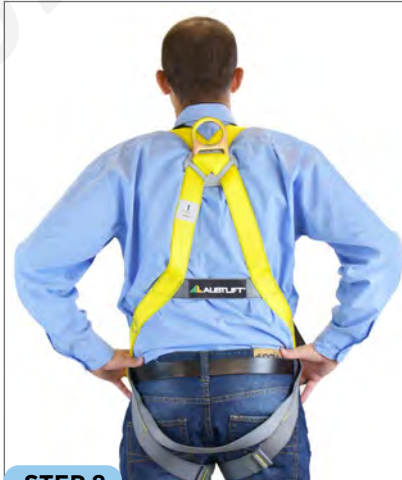

STEP 8

Once fitted adjust all straps to ensure the harness is fitted securely to the body and get your work mate to check it over for you.

When using the front webbing loops ensure they are always brought together and connected with an approved connector.
Never use the front webbing loops singularly.

WARNING: Failing to fit or maintain harness properly may cause serious injury or death.

NOTICE: please note this instruction does not replace or remove the need for the end user of all safety products to undergo competence based training.

Suspension Trauma Strap Connection

Suspension Trauma Straps are designed to avoid the effect of Suspension Trauma. Compact and light weight without hampering the activity of the worker. Allows the suspended worker to stand up in their harness to relieve pressure after falling. Easy to attach to the Harness and easy to deploy.



Fall Protection
Equipment

Suspension Trauma Strap Connection

Suspension Trauma Straps are designed for your safety and survival. Suspension Trauma Straps are not a substitute for effective and fast rescue. A rescue plan should form part of the Safe Work Method for all work conducted at height.

WARNING: THIS IS NOT A RESCUE PLAN, IT IS JUST FOR THE CASUALTY'S COMFORT.

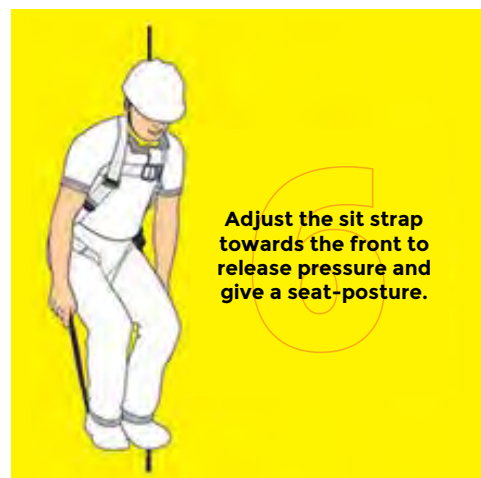
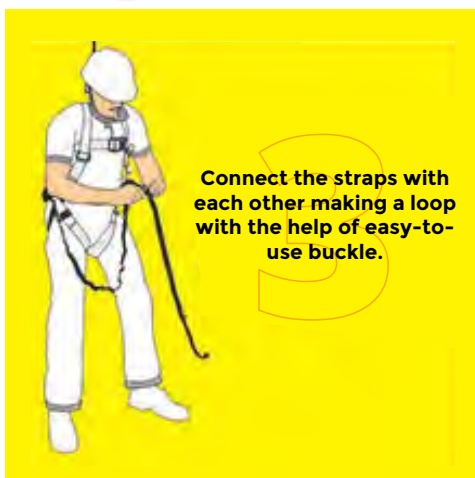
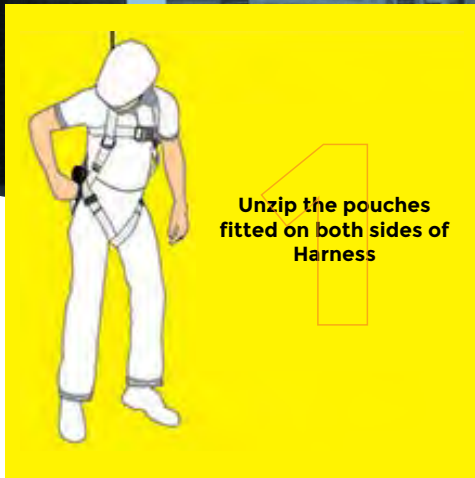

Harnesses & Belts

Selection made easy with Austlift Harness

We have developed symbols to aid you in selecting the right harness to suit your particular work application requirement. These symbols represent work application and harness attachments.

This catalogue also utilizes these unique symbols throughout the personal protection equipment range to best describe your particular work application.

If you have any further questions regarding your personal protection needs, require further information, you can contact your local distributor or Australian Lifting Centre Sydney head office on 1300 100 120.



Positioning Restraint



Confined Space Entry



Rescue



Construction & maintenance



Ladder Work



Scaffolding



Warehouse



Roofing Work



Utilities



Tower Work

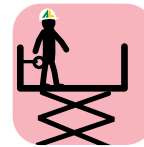

Elevated Work Platforms

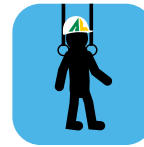

Suspension



BMP No. 672857	AS/NZS1891.1:2020
BMP No. 739186	AS1891.3:2020
BMP No. 739185	AS1891.5:2020
BMP No. 672858	AS/NZS5532:2013

Fall Protection Equipment

CORE Tradesman Harness

CODE: 915001

Full body harness with large upright dorsal d-ring and front chest loops for fall arrest. Adjustable shoulder, chest and leg straps. Certified to AS/NZS 1891.1

SUITABLE FOR: construction & maintenance, ladder work, scaffolding, warehouse, roofing work.

- Large permanently upright D-ring fall arrest rated.
- 2/3 bar buckle connection.
- Fall arrest frontal belay loops.
- Certified & Approved to AS/NZS 1891.1.
- The standard harness is a one-size-fits-most covering M - XXL.
- Spec sheet available on the website.

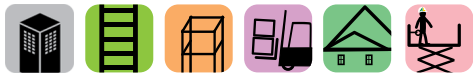

Suspension Trauma Strap NOT INCLUDED
Sold separately PC. 915075



1. Permanent Upright Dorsal D-ring: Stamped Alloy Steel with Splitted Polymer Sleeve which prevents the webbing from being damaged by the metallic contact of dorsal D-ring. MBS 23kN, Proof Load Tested.



2. Adjustable Buckle: provided with pull grip feature to enable easy pull down with thumb and easy to adjust straps for a good lift.



3. Combination Buckle: Stamped Alloy Steel, MBS 15kN

4. Product Label: with protection sleeve.

5. Fall arrest & Retrieval attachment loops: The loops at the ends are protected by an abrasion resistant covering. This prevents the webbing from being damaged by the metallic contact of the connector.



Mid Range Standard Features	
6. Polyester webbing:	44mm width and designed with unique aesthetic stitch pattern for enhanced stitching strength with smart styling.
7. Elastic Loops:	Designed to retain the excess strap while adjustment.
8. Adjustable Chest Strap:	Equipped with elastic loops to enable the user to bring chest strap in required position.
9. Adjustable Thigh Strap:	Equipped with elastic loops to enable the user to bring thigh strap in required position.
10. Ideally Positioned Sit Strap:	Designed for long lasting comfort.
11. Marking:	Denotes attachment point for fall arrest.
12. Marking:	Denotes attachment point for fall arrest (& confined space entry).
13. Dorsal Attachment Point:	For attachment for fall arrest, enables straight upright position in the event of a fall.
14. Frontal Attachment Point:	For attachment for fall arrest, enables easy connection in the event of a fall.

CORE Tradesman Plus Harness

CODE: 915002

Full body harness with 1.8m webbing lanyard and snap hook permanently attached. Certified to AS/NZS 1891.1 (Harness Component) and AS 1891.5 standards (Lanyard Component)

- Large permanently upright D-ring fall arrest rated.
- 2/3 bar buckle connection.
- Fall arrest frontal belay loops.
- 1.8M shock absorbing lanyard with snap hook attached.
- Certified & Approved to AS/NZS 1891.1.
- The standard harness is a one-size-fits-most covering M - XXL.
- Spec sheet available on the website.

SUITABLE FOR: construction & maintenance, warehouse, roofing work and elevated work platforms.



Suspension Trauma Strap NOT INCLUDED
Sold separately PC. 915075



1. Permanent Upright Dorsal D-ring: Stamped Alloy Steel with Splitted Polymer Sleeve which prevents the webbing from being damaged by the metallic contact of dorsal D-ring. MBS 23kN, Proof Load Tested.



2. Product Label: with protection sleeve.

3. Snap Hook: Alloy Steel, Meets ANSI Z359.12-2009, 16kN Gate, MBS 23kN, 20mm Opening.

4. Abrasion Resistant Covering: prevents the webbing from being damaged by metallic contact of the connector.



5. Energy Absorber: 140kg rated energy absorber.

6. Single Webbing Lanyard: Permanent attached to the D-ring, 44mm Width, 1.8M Length, Max. Free fall 2M, AS 1891.4 with ANSI D/A hook.

7. Fall arrest & Retrieval attachment loops: The loops at the ends are protected by an abrasion resistant covering. This prevents the webbing from being damaged by the metallic contact of the connector.

8. Adjustable Buckle: provided with pull grip feature to enable easy pull down with thumb and easy to adjust straps for a good lift.

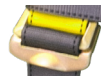

9. Combination Buckle: Stamped Alloy Steel, MBS 15kN



Mid Range Standard Features

10. Polyester webbing:	44mm width and designed with unique aesthetic stitch pattern for enhanced stitching strength with smart styling.
11. Elastic Loops:	Designed to retain the excess strap while adjustment.
12. Adjustable Chest Strap:	Equipped with elastic loops to enable the user to bring chest strap in required position.
13. Adjustable Thigh Strap:	Equipped with elastic loops to enable the user to bring thigh strap in required position.
14. Ideally Positioned Sit Strap:	Designed for long lasting comfort.
15. Marking:	Denotes attachment point for fall arrest.
16. Marking:	Denotes attachment point for fall arrest and retrieval.
17. Dorsal Attachment Point:	For attachment for fall arrest, enables straight upright position in the event of a fall.
18. Frontal Attachment Point:	For attachment for fall arrest, enables easy connection in the event of a fall.

CORE Tradesman Plus Harness with QR Buckles

CODE: 915002QR

Full body harness with 1.8m webbing lanyard and snap hook permanently attached. Certified to AS/NZS 1891.1 (Harness Component) and AS 1891.5 standards (Lanyard Component)

SUITABLE FOR: hire industry, construction, maintenance, warehousing, elevated work platforms and has space for corporate branding.

- Large permanently upright D-ring fall arrest rated.
- Quick Release Buckle connection.
- Fall arrest frontal belay loops.
- 1.8M shock absorbing lanyard with snap hook attached.
- Certified & Approved to AS/NZS 1891.1.
- The standard harness is a one-size-fits-most covering M-XXL.
- Spec sheet available on the website.



Suspension Trauma Strap NOT INCLUDED
Sold separately PC. 915075



1. Permanent Upright Dorsal D-ring: Stamped Alloy Steel with Splitted Polymer Sleeve which prevents the webbing from being damaged by the metallic contact of dorsal D-ring. MBS 23kN, Proof Load Tested.



2. Product Label: with protection sleeve.

3. Snap Hook: Alloy Steel, Meets ANSIZ359.12-2009, 16kN Gate, MBS 23kN, 20mm Opening.

4. Abrasion Resistant Covering: prevents the webbing from being damaged by metallic contact of the connector.



5. Energy Absorber: 140kg rated energy absorber.

6. Single Webbing Lanyard: Permanent attached to the D-ring, 44mm Width, 1.8M Length, Max. Free fall 2M, AS 1891.4 with ANSI D/A hook.

7. Fall arrest & Retrieval attachment loops: The loops at the ends are protected by an abrasion resistant covering. This prevents the webbing from being damaged by the metallic contact of the connector.

8. Adjustable Buckle: provided with pull grip feature to enable easy pull down with thumb and easy to adjust straps for a good lift.



9. Quick Release Buckle: Extremely easy to use with single hand. Designed with Lock indicator. Made of stamped alloy steel, MBS: 15kN.



Mid Range Standard Features	
10. Polyester webbing:	44mm width and designed with unique aesthetic stitch pattern for enhanced stitching strength with smart styling.
11. Elastic Loops:	Designed to retain the excess strap while adjustment.
12. Adjustable Chest Strap:	Equipped with elastic loops to enable the user to bring chest strap in required position.
13. Adjustable Thigh Strap:	Equipped with elastic loops to enable the user to bring thigh strap in required position.
14. Ideally Positioned Sit Strap:	Designed for long lasting comfort.
15. Marking:	Denotes attachment point for fall arrest.
16. Marking:	Denotes attachment point for fall arrest and retrieval.
17. Dorsal Attachment Point:	For attachment for fall arrest, enables straight upright position in the event of a fall.
18. Frontal Attachment Point:	For attachment for fall arrest, enables easy connection in the event of a fall.

CORE Cross Over Harness CODE: 915004

The CORE Cross Over is a new crosslink design featuring floating shoulder and leg straps. The harness includes two attachment points located on the centre front and centre back. Suitable for fall arrest from both front and rear D-rings. Certified to: AS/NZS 1891.1.

- Large permanently upright D-ring fall arrest rated.
- 2/3 bar buckle connection.
- Fall arrest frontal belay loops.
- Certified & Approved to AS/NZS 1891.1.
- The standard harness is a one-size-fits-most covering M-XXL.
- Spec sheet available on the website.

SUITABLE FOR: construction & maintenance, warehouse, roofing work and elevated work platforms.



Suspension Trauma Strap NOT INCLUDED
Sold separately PC. 915075



- 1. Dorsal D-ring:** Made of Alloy Steel, Proof Load Tested.
- 2. Chest D-ring:** Made of Alloy Steel, Proof Load Tested.
- 3. Product Label:** With Protection Sleeve.
- 4. Adjustable Buckle:** Made of Alloy Steel. Pull down with thumb and easy to adjust straps.
- 5. Combination Buckle:** Stamped Alloy Steel, MBS 15kN



Mid Range Standard Features	
6. Polyester webbing:	44mm width and designed with unique aesthetic stitch pattern for enhanced stitching strength with smart styling.
7. Plastic Loops:	Equipped with unique sliding chest strap plates to enable the user to bring chest strap in required position.
8. Adjustable Chest Strap:	Equipped with elastic loops to enable the user to bring chest strap in required position.
9. Adjustable Thigh Strap:	Equipped with elastic loops to enable the user to bring thigh strap in required position.
10. Ideally Positioned Sit Strap:	Designed for long lasting comfort.
11. Marking:	Denotes attachment point for fall arrest.
12. Marking:	Denotes attachment point for fall arrest.
13. Dorsal Attachment Point:	For attachment for fall arrest, enables straight upright position in the event of a fall.
14. Frontal Attachment Point:	For attachment for fall arrest, enables easy connection in the event of a fall.

Fall Protection Equipment

CORE Total Restraint Belt

CODE: 915072/915073/915074

The Work Positioning System comprises of a work positioning body belt along with work positioning lanyard. This enables the worker to work at heights in a well supported position with both his hands free. The Work Positioning Body Belts and Work Positioning Lanyards, however, should not be used for Fall Protection AUSTLIFT Work Positioning Body Belts have a sliding belt on the comfort pad which enables the user to easily position the adjustment buckle of the belt at the center of his waist for smooth functioning.

- Optimum width comfort pad to provide sufficient lumbar support for long working hours
- Fully Adjustable
- Width of Back pad: 20 cms.
- One Dorsal D-Rings
- Rings for tool holders, bolt bags, etc
- Available in sizes: Medium, Large, Extra Large
- Static load tested to 12kN



SUITABLE FOR: Utilities, Positioning Restraint



Code: 915072	Size: M	Length=1260mm	Tested to 12kN static load for 3 minutes
Code: 915073	Size: L	Length=1360mm	
Code: 915074	Size: XL	Length=1460mm	

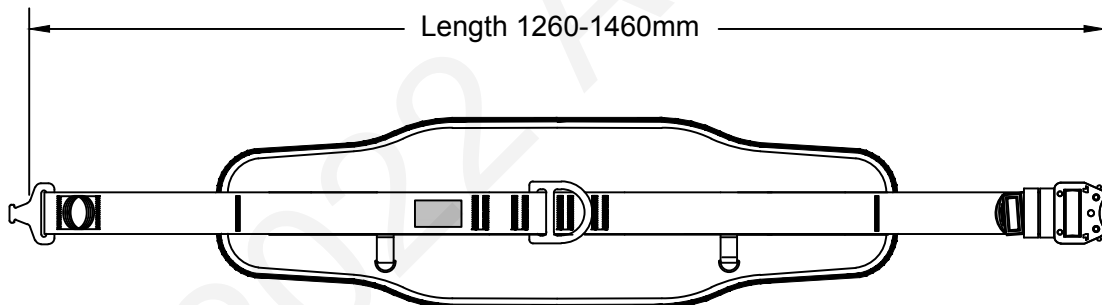

PRIME Riggers Harness CODE: 915003

Full body harness with large upright dorsal d-ring and front chest d-ring for fall arrest. Adjustable shoulder, chest and leg straps. Confined space loops and quick connect buckles. Suspension trauma straps included. Certified to ASNZS 1891.1

SUITABLE FOR: Confined space rescue, construction & maintenance, ladder work, scaffolding, warehouse, roofing work and elevated work platforms.

- Large permanently upright D ring fall arrest rated.
- Small chest D-ring attached.
- Quick Release Buckles connection.
- Confined Space Shoulder Loops.
- Certified & Approved to AS/NZS 1891.1.
- The standard harness is a one-size-fits-most covering M-XXL.
- Available in sizes: S, M-XXL, XXL+.
- Spec sheet available on the website.



915003S Size: **S**

915003 Size: **M-XXL**

915003L Size: **XXL+**

Suspension Trauma Strap included



1. Permanent Upright Dorsal D-ring: Made of stamped alloy steel, MBS 23kN, Proof load tested.



2. Retrieval attachment & Confine Space Shoulder Loops



3. Chest D-ring: Made of forged alloy steel, MBS 23kN, Proof Load Tested. Inner Bar protects the webbing from being damaged by metallic contact.



4. Quick Release Buckle: Extremely easy to use with single hand. Designed with Lock indicator. Made of stamped alloy steel, MBS: 15kN.



5. Adjustable Buckle: provided with pull grip feature to enable easy pull down with thumb and easy to adjust straps for a good lift.



6. Thigh Seat Connector: Designed for connecting thigh strap and site strap with a extra web, stitched in an unique aesthetic pattern for enhanced stitching strength with smart styling.



Mid Range Standard Features

7. Product Label:	Product Label with protection sleeve.
8. Polyester webbing:	44mm width and designed with unique aesthetic stitch pattern for enhanced stitching strength with smart styling.
9. Web Keeper:	Designed for minimizing the chances of accidental opening of web ends, hence ensure the harness is snugly fit at all times. It gives better grip while adjustment.
10. Elastic Loops:	Designed to retain the excess strap while adjustment.
11. Adjustable Chest Strap:	Equipped with elastic loops to enable the user to bring chest strap in required position.
12. Adjustable Thigh Strap:	Equipped with elastic loops to enable the user to bring thigh strap in required position.
13. Ideally Positioned Sit Strap:	Designed for long lasting comfort.
14. Marking:	Denotes attachment point for fall arrest.
15. Marking:	Denotes attachment point for fall arrest.
16. Marking:	Denotes attachment point for retrieval.
17. Dorsal Attachment Point:	For attachment for fall arrest, enables straight upright position in the event of a fall.
18. Frontal Attachment Point:	For attachment for fall arrest, enables easy connection in the event of a fall.
19. Shoulder Attachment Point:	For attachment for confined space entry, enables easy connection in the event of a rescue.

PRIME Positioning Harness

CODE:915005

Full body harness with large D-ring and front chest d-ring for fall arrest. Adjustable shoulder, chest and leg strap. Padded waist belt with side d-rings for work positioning. Quick connect buckles and suspension trauma straps included. Certified to AS/NZS 1891.1

- Large permanently upright D ring fall arrest rated.
- Small chest D ring attached.
- Two Side D rings attached.
- Quick Release Buckles connection.
- Waist Padding.
- Certified & Approved to AS/NZS 1891.1.
- The standard harness is a one-size-fits-most covering M - XXL.

SUITABLE FOR: Confined space rescue, construction & maintenance, ladder work, scaffolding, warehouse, roofing work, tower work and elevated work platforms.

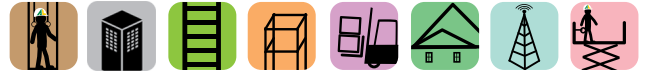

Spec sheet available on the website

1. Permanent Upright Dorsal D-ring: stamped alloy steel with polymer sleeve prevents the webbing from being damaged by the metallic contact. MBS 23kN, Proof Load Tested.



Suspension Trauma Strap included



2. Chest D-ring: Made of forged alloy steel, MBS 23kN, Proof Load Tested. Inner Bar protects the webbing from being damaged by metallic contact.



3. Quick Release Buckle: Made of stamped alloy steel. Extremely easy to use with single-hand. Designed with Lock indicator. MBS: 15kN.



4. Work Positioning Belt: Fully padded with mesh pads for better comfort and air circulation. Equipped with quick release buckles for easy adjustment.

5. Large Lateral D-ring: Made of stamped alloy steel with polymer sleeve prevents the webbing from being damaged by the metallic contact. Specially designed with a bend to stand out for easy attachment. MBS 23kN, Proof Load Tested.



6. Adjustable Buckle: provided with pull grip feature to enable easy pull down with thumb and easy to adjust straps for a good lift.



7. Thigh Seat Connector: Designed for connecting thigh strap and site strap with a extra web, stitched in an unique aesthetic pattern for enhanced stitching strength with smart styling.



Mid Range Standard Features

8. Product Label:	Product label with protection sleeve.
9. Polyester webbing:	44mm width and designed with unique aesthetic stitch pattern for enhanced stitching strength with smart styling.
10. Web Keeper:	Designed for minimizing the chances of accidental opening of web ends, hence ensure the harness is snugly fit at all times. It gives better grip while adjustment.
11. Elastic Loops:	Designed to retain the excess strap while adjustment.
12. Adjustable Chest Strap:	Equipped with elastic loops to enable the user to bring chest strap in required position.
13. Adjustable Thigh Strap:	Equipped with elastic loops to enable the user to bring thigh strap in required position.
14. Adjustable Waist Strap:	Equipped with elastic loops to enable the user to bring waist strap in required position.
15. Ideally Positioned Sit Strap:	Designed for long lasting comfort.
16. Marking:	Denotes attachment point for fall arrest.
17. Marking:	Denotes attachment point for work positioning.
18. Dorsal Attachment Point:	For attachment for fall arrest, enables straight upright position in the event of a fall.
19. Frontal Attachment Point:	For attachment for fall arrest, enables easy connection in the event of work positioning.
20. Lateral Attachment Points:	For attachment for work positioning, designed with a bend to stand out for easy attachment.

PRIME Comfort Harness CODE:915008

Full body harness with dorsal d-ring and chest d-ring for fall arrest. Adjustable shoulder, chest and leg straps, quick connect buckles. Padded shoulder and leg straps, confined space loops and aluminium fittings. Label pack included. Certified to ASNZS 1891.1

- Large permanently upright D ring fall arrest rated.
- Small chest D ring attached.
- Quick Release Buckles connection.
- Leg Padding & Shoulder padding.
- Confined Space Shoulder Loops.
- Certified & Approved to AS/NZS 1891.1.
- The standard harness is a one-size-fits-most covering M - XXL.

SUITABLE FOR: Confined space rescue, construction & maintenance, ladder work, scaffolding, warehouse, roofing work and elevated platforms.



915008S Size: **S**

915008 Size: **M-XXL**

915008L Size: **XXL+**

Suspension Trauma Strap included 



Spec sheet available on the website





1. Permanent Upright Dorsal D-ring: Made of forged aluminium alloy. Designed with a bend to stand out for easy attachment to the lanyard. MBS: 23kN. Proof Load Tested. 

2. Fall arrest & Confine Space Shoulder Loops

3. Padded Shoulder Strap: The distinctively placed fully padded straps with knitted mesh for better comfort and air circulation.

4. Chest D-ring: Made of forged alloy steel, MBS 23kN, Proof Load Tested. Inner Bar protects the webbing from being damaged by metallic contact when connecting hooks to the D-ring. 

5. Adjustable Buckle: Provided with pull grip feature to enable easy pull down with thumb and easy to adjust straps for a good lift. 

6. Quick Release Buckle: Extremely easy to use with single-hand. Designed with Lock indicator. Made of stamped alloy steel, MBS: 15kN. 

7. Padded Thigh Strap: The distinctively placed fully padded straps with Quick release buckles allows easy adjustment. The knitted mesh net used in the pads maintains proper air circulation.

8. Thigh Seat Connector: Designed for connecting thigh strap and site strap with a extra web, stitched in an unique aesthetic pattern for enhanced stitching strength with smart styling.



Premium Range Standard Features	
9. Product Label:	Product label with protection sleeve.
10. Polyester webbing:	44mm width and designed with unique aesthetic stitch pattern for enhanced stitching strength with smart styling.
11. Web Keeper:	Designed for minimizing the chances of accidental opening of web ends, hence ensure the harness is snugly fit at all times. It gives better grip while adjustment.
12. Elastic Loops:	Designed to retain the excess strap while adjustment.
13. Adjustable Chest Strap:	Equipped with elastic loops to enable the user to bring chest strap in required position.
14. Ideally Positioned Sit Strap:	Designed for long lasting comfort.
15. Marking:	Denotes attachment point for fall arrest (& confined space entry).
16. Dorsal Attachment Point:	For attachment for fall arrest, enables straight upright position in the event of a fall.
17. Frontal Attachment Point:	For attachment for fall arrest, enables easy connection in the event of a fall.

Fall Protection Equipment

PRIME Endure Stainless Steel Harness

CODE: 915018

The Stainless steel fittings and repel technology coating makes this a durable long lasting harness in highly corrosive environments. Constructed from a unique polyester webbing, incorporating the special repel technology - which repels oil, dirt and water. The coating does not impact weight, feel, colour and texture of the webbing. Liquid spills can easily be wiped away when blotted with a clean cloth, and dry soil can be brushed off easily.

- Oil, Dirt and water repellent webbing.
- Highly UV Resistant Webbing
- Large permanently upright D-ring fall arrest rated.
- Stainless Steel 2/3 bar buckle connection.
- Fall arrest frontal belay loops.
- Certified & Approved to AS/NZS 1891.1.
- The standard harness is a one-size-fits-all covering M - XXL.
- Spec sheet available on the website.

SUITABLE FOR: construction & maintenance, ladder work, scaffolding, warehouse, roofing work.



Suspension Trauma Strap NOT INCLUDED
Sold separately PC. 915075



1. Permanent Upright Dorsal D-ring: Stamped Stainless Steel with Splitted Polymer Sleeve which prevents the webbing from being damaged by the metallic contact of dorsal D-ring. MBS 23kN, Proof Load Tested.



2. Adjustable Buckle: provided with pull grip feature to enable easy pull down with thumb and easy to adjust straps for a good lift.



3. Retrieval attachment confine space shoulder loops

4. Combination Buckle: Stainless Steel, MBS 15kN

5. Product Label: with protection sleeve.

6. Fall arrest & Retrieval attachment loops: The loops at the ends are protected by an abrasion resistant covering. This prevents the webbing from being damaged by the metallic contact of the connector.

7. Special Repellent Webbing: It's oil, dirt and water repellent hence provides excellent resistance from build up of oil and dirt. Highly tear and cut resistant because does not allow abrasion due to collection of dust or dirt. Highly UV resistant webbing. Easy maintenance wipes clean in seconds.



Mid Range Standard Features	
8. Elastic Loops:	Designed to retain the excess strap while adjustment.
9. Adjustable Chest Strap:	Equipped with elastic loops to enable the user to bring chest strap in required position.
10. Adjustable Thigh Strap:	Equipped with elastic loops to enable the user to bring thigh strap in required position.
11. Ideally Positioned Sit Strap:	Designed for long lasting comfort.
12. Marking:	Denotes attachment point for fall arrest.
13. Marking:	Denotes attachment point for fall arrest (& confined space entry).
14. Dorsal Attachment Point:	For attachment for fall arrest, enables straight upright position in the event of a fall.

PRIME Hot Works Harness

CODE: 915017

This harness is made with Aramid webbing and Aramid thread to help keep welding and grinding sparks damage to a minimum.

Taking all the great features of the Full Body Harness, with confined space loops on the shoulder straps to make it suitable for workers in confined space environments.

The shoulder loops can be used with a spreader bar during emergency retrieval situations to comfortably raise or lower the user. Certified to: AS/NZS 1891.1.

SUITABLE FOR: Construction & maintenance, warehouse, roofing work and elevated platforms.

- Self extinguishing fabric, will not catch alight.
- Protection against arcing.
- Adjustable sides for a secure fit.
- Lightweight and easy to wear.
- Confined Space shoulder loops and frontal loops.
- The standard harness is a one-size-fits-most covering M - XXL.
- Spec sheet available on the website.



Suspension Trauma Strap NOT INCLUDED
Sold separately PC. 915075



1. Dorsal D-ring: Made of stainless steel. Designed with flat structure allows comfort wearing.

2. Fall Arrest & Confine Space Shoulder Loops

3. Fall Arrest & Rtrivel Attachment Frontal Loops

4. Adjustable Buckle: Made of Stainless steel. Designed to adjust straps for a good lift.

5. Pulling Grip Strap: Designed to easily adjust straps for a good lift

6. Aramid Webbing: Made with Aramid webbing and aramid thread. High heat aramid thread used to help keep welding and grinding sparks damage to a minimum.



Premium Range Standard Features	
7. Elastic Loops:	Designed to retain the excess strap while adjustment.
8. Adjustable Chest Strap:	Equipped with elastic loops to enable the user to bring chest strap in required position.
9. Adjustable Shoulder Strap:	Equipped with elastic loops to enable the user to bring shoulder strap in required position.
10. Adjustable Thigh Strap:	Equipped with elastic loops to enable the user to bring thigh strap in required position.
11. Ideally Positioned Sit Strap:	Designed for long lasting comfort.
12. Marking:	Denotes attachment point for fall arrest.
13. Marking:	Denotes attachment point for retrieval (confined space entry).
14. Dorsal Attachment Point:	For attachment for fall arrest, enables straight upright position in the event of a fall.
15. Retrieval Attachment Point:	For attachment for Retrieval, enables straight upright position in the event of a rescue.
16. Frontal Attachment Point:	For attachment for fall arrest, enables easy connection in the event of a fall.

PRIME Hot Works Plus Harness

CODE: 915016

This harness is made with Aramid webbing and Aramid thread to help keep welding and grinding sparks damage to a minimum. Upgraded into quick release buckle.

Taking all the great features of the Full Body Harness, with confined space loops on the shoulder straps to make it suitable for workers in confined space environments.

The shoulder loops can be used with a spreader bar during emergency retrieval situations to comfortably raise or lower the user. Certified to: AS/NZS 1891.1.

- Upgraded into Quick release buckle.
- Self extinguishing fabric, will not catch alight.
- Protection against arcing.
- Adjustable sides for a secure fit.
- Lightweight and easy to wear.
- Confined Space shoulder loops and frontal loops.
- The standard harness is a one-size-fits-most covering M - XXL.
- Spec sheet available on the website.

SUITABLE FOR: Construction & maintenance, warehouse, roofing work and elevated platforms.



1. Dorsal D-ring: Made of alloy steel. Designed with flat structure allows comfort wearing.

2. Confine Space Shoulder Loops

3. Fall Arrest & Retrieval Attachment Frontal Loops

4. Quick Release Buckle: Made of alloy steel. Designed to adjust straps for a good lift.

5. Pulling grip strap: Designed to easily adjust straps for a good lift.

6. Aramid Webbing: Made with Aramid webbing and aramid thread. High heat aramid thread used to help keep welding and grinding sparks damage to a minimum.

Suspension Trauma Strap included



Premium Range Standard Features	
7. Elastic Loops:	Designed to retain the excess strap while adjustment.
8. Adjustable Chest Strap:	Equipped with elastic loops to enable the user to bring chest strap in required position.
9. Adjustable Shoulder Strap:	Equipped with elastic loops to enable the user to bring shoulder strap in required position.
10. Adjustable Thigh Strap:	Equipped with elastic loops to enable the user to bring thigh strap in required position.
11. Ideally Positioned Sit Strap:	Designed for long lasting comfort.
12. Marking:	Denotes attachment point for fall arrest.
13. Marking:	Denotes attachment point for retrieval (confined space entry).
14. Dorsal Attachment Point:	For attachment for fall arrest, enables straight upright position in the event of a fall.
15. Retrieval Attachment Point:	For attachment for Retrieval, enables straight upright position in the event of a rescue.
16. Frontal Attachment Point:	For attachment for fall arrest, enables easy connection in the event of a fall.

Fall protection Equipment

PRIME Comfort Restraint Harness

CODE:915009

Full body harness with dorsal d-ring and chest d-ring for fall arrest. Adjustable shoulder, chest and leg straps, quick connect buckles. Padded shoulder and leg straps, confined space loops and aluminium fittings. Label pack included. Certified to ASNZS 1891.1

SUITABLE FOR: Confined space rescue, construction & maintenance, ladder work, scaffolding, warehouse, roofing work and elevated platforms.

- Large permanently upright D ring fall arrest rated.
- Small chest D ring attached.
- Quick Release Buckles connection.
- Leg Padding & Shoulder padding.
- Confined Space Shoulder Loops.
- Certified & Approved to AS/NZS 1891.1.
- The standard harness is a one-size-fits-most covering M - XXL.



Suspension Trauma Strap included 



1. Permanent Upright Dorsal D-ring: Made of forged aluminium alloy. Designed with a bend to stand out for easy attachment to the lanyard. MBS: 23kN. Proof Load Tested. 

2. Fall arrest & Confine Space Shoulder Loops

3. Padded Shoulder Strap: The distinctively placed fully padded straps with knitted mesh for better comfort and air circulation.

4. Chest D-ring: Made of forged alloy steel, MBS 23kN, Proof Load Tested. Inner Bar protects the webbing from being damaged by metallic contact when connecting hooks to the D-ring. 

5. Adjustable Buckle: Provided with pull grip feature to enable easy pull down with thumb and easy to adjust straps for a good lift. 

6. Quick Release Buckle: Extremely easy to use with single-hand. Designed with Lock indicator. Made of stamped alloy steel, MBS: 15kN. 

7. Padded Thigh Strap: The distinctively placed fully padded straps with Quick release buckles allows easy adjustment. The knitted mesh net used in the pads maintains proper air circulation.

8. Thigh Seat Connector: Designed for connecting thigh strap and site strap with a extra web, stitched in an unique aesthetic pattern for enhanced stitching strength with smart styling.

9. Detachable Waist Belt: Designed with 65x20cm padding. Equipped with total restraint steel D-Ring and steel quick release buckle. Total length: 126cm. 



Premium Range Standard Features	
10. Product Label:	Product label with protection sleeve.
11. Polyester webbing:	44mm width and designed with unique aesthetic stitch pattern for enhanced stitching strength with smart styling.
12. Web Keeper:	Designed for minimizing the chances of accidental opening of web ends, hence ensure the harness is snugly fit at all times. It gives better grip while adjustment.
13. Elastic Loops:	Designed to retain the excess strap while adjustment.
14. Adjustable Chest Strap:	Equipped with elastic loops to enable the user to bring chest strap in required position.
15. Ideally Positioned Sit Strap:	Designed for long lasting comfort.
16. Marking:	Denotes attachment point for fall arrest (& confined space entry).
17. Dorsal Attachment Point:	For attachment for fall arrest, enables straight upright position in the event of a fall.
18. Frontal Attachment Point:	For attachment for fall arrest, enables easy connection in the event of a fall.

Fall Protection Equipment

PRIME Tower Harness CODE: 915010

Tower harness complete with dorsal extension strap, confined space rescue loops, chest belay loops, aluminium buckles, side D-rings with waist pad for full work positioning. Certified to AS/NZS1891.1

SUITABLE FOR: Confined space rescue, construction & maintenance, ladder work, scaffolding, tower work and elevated platforms.

- Large permanently upright D-ring fall arrest rated.
- Aluminium Alloy buckles and Hooks.
- Fall arrest frontal belay loops.
- Confined Space Shoulder Loops.
- 2 Large o-ring on both sides.
- Tool Loops on waist belt.
- Waist and bottom padding.
- The standard harness is a one-size-fits-most covering M - XXL.
- Spec sheet available on the website.



Suspension Trauma Strap NOT INCLUDED
Sold separately PC. 915075

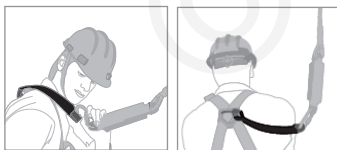

1. Permanent Upright Dorsal D-ring: made of forged aluminium alloy, MBS 23kN, Proof Load Tested.

2. Extension Strap: Incorporated on the dorsal D-ring of the harness has a D-ring attached on the other side. Can be used to connect to the rescue equipment. It allows easy rescue and minimizes the discomfort while being rescued. The extension Strap allows the user to easily connect to or disengage himself from dorsal attachment D-ring without external help. The extension strap lies on the harness webbing with the help of Velcro binding, when not in use.

3. Fall arrest attachment & Confine Space Shoulder Loops

4. Fall arrest attachment chest loops

5. Adjustable Buckle: provided with pull grip feature to enable easy pull down with thumb and easy to adjust straps for a good lift.



6. Combination Buckle: Stamped Aluminium Alloy, MBS 15kN

7. Lateral O-ring: Made of forge alloy steel with a golden yellow galvanized finish. MBS: 23kN.

8. Lateral D-rings: Made of forged aluminium alloy. Designed with a bend to stand out enables easy attachment to the work position lanyard. MBS: 23kN, Proof Load Tested.



9. Work Positioning Belt: Fully padded with knitted mesh pads for better comfort and air circulation. Equipped with quick release buckle allows easy adjustment.

10. Holding Loops: The Work positioning belt is provided with holding loops for attaching tool bag etc.

11. Ideally Positioned Sit Pad: equipped with soft pads, designed for long lasting comfort.



Special Range Standard Features

12. Product Label:	With protection sleeve.
13. Polyester webbing:	44mm width and designed with unique aesthetic stitch pattern for enhanced stitching strength with smart styling.
14. Web Keeper:	Designed for minimizing the chances of accidental opening of web ends, hence ensure the harness is snugly fit at all times. It gives better grip while adjustment.
15. Elastic Loops:	Designed to retain the excess strap while adjustment.
16. Adjustable Chest Strap:	Equipped with elastic loops to enable the user to bring chest strap in required position.
17. Adjustable Thigh Strap:	Equipped with elastic loops to enable the user to bring chest strap in required position.
18. Velcro	Loop Side & Hook Side.
19. Marking:	Denotes attachment point for application attachment.

MaxiPro Elect Tower Harness

CODE: 915011

The Elect Tower Harness has been developed following extensive consultation with our power utility end-users, giving them the features they desire most.

This premium harness has been designed to eliminate restriction on the shoulders, allowing total upper body movement. Flexible, water-resistant padding on waist and seat allows continued comfort for long periods of time, even while sitting in a vehicle.

Reduced obstructions on the top of the harness help prevent entanglement while working through power lines. Adjustable seat that can be adjusted to allow for comfortable seating during pole strap work. This unique feature allows the user to customise the seat to their work style. Certified to: AS/NZS 1891.1.

- Large lateral D-Ring for Pole strap attachment points.
- Glove and barriered from waist up.
- Fall arrest chest frontal loops for fall arrest attachment points.
- Easy donning & doffing due to the quick release buckles and specialised design.
- Y-shaped back reduces the pressure on the upper torso allowing more freedom to reach out.
- Bright webbing allows for higher visibility under work lights.
- Rear buckle to allow for adjustment of the back webbing ring (this allows for users of different heights to be comfortable).
- The standard harness is a one-size-fits-most covering M - XXL.

SUITABLE FOR: Positioning Restraint, construction & maintenance, warehouse, Tower Work, elevated platforms.



1. Webbing Dorsal Ring

2. Lateral O-rings: Made of Alloy Steel. Designed to enable easy pole strap attachment.

3. Plastic Quick Release Buckle on the Chest

4. Work Positioning Belt: Fully padded with mesh pads for better comfort and air circulation. Equipped with aluminium adjustable buckles.

5. Adjustable Padded Seat Strap: The distinctively placed fully padded straps with Quick release buckles allows easy adjustment. The knitted mesh net used in the pads maintains proper air circulation.

6. Glove and Barriered from Waist up.

7. Adjustable Buckle: Made of Aluminium alloy. Provided with pulling grip strap to easily adjust straps for a good lift.

8. Quick Release Buckle: Extremely easy to use with single-hand. Made of aluminium alloy.

9. Seat Configuration Strap: Specially designed and to meet all purposes and provide better support than others.

10. Fall arrest attachment chest loops: The loops at the ends are protected by an abrasion resistant covering. This prevents the webbing from being damaged by the metallic contact of the connector.

11. Holding Loop Rings: Attached to the work positioning belt for attaching tools.



Premium Range Standard Features	
12. Polyester webbing:	Flexible, water-resistant padding on waist and seat allows continued comfort for long periods of time, even while sitting in a vehicle.
13. Elastic Loops:	Designed to retain the excess strap while adjustment.
14. Adjustable Back Strap:	Equipped with rear buckle for adjustment of back webbing ring to allow comfort use for different heights.
15. Adjustable Chest Strap:	Equipped with elastic loops to enable the user to bring chest strap in required position.
16. Adjustable Thigh Strap:	Equipped with elastic loops to enable the user to bring thigh strap in required position.
17. Adjustable Waist Strap:	Equipped with elastic loops to enable the user to bring waist strap in required position.
18. Dorsal Attachment Point:	For attachment for fall arrest, enables straight upright position in the event of a fall.
19. Frontal Attachment Points:	For attachment for fall arrest, enables easy connection in the event of a fall.
20. Lateral Attachment Points:	For attachment for work positioning, designed with a bend to stand out for easy attachment.

Fall Protection Equipment

MaxiPro All Purpose Harness

CODE: 915012

The All Purpose Harness is an innovative design allowing the user full adjustment on the chest, legs and position of the Dorsal D-Ring that fits more users more comfortably.

The webbing-to-buckle adjustment relationship is critical to happy users, as well as the ease of putting on the harness. In the event of a fall the durable Polyester webbing in our design evenly distributes the impact over the thighs, torso and buttocks.

Our arrest products are designed to meet the high demands of the industry, and the high-quality fittings and easy adjustability of the SBEMT model ensures high user acceptance. Certified to ASNZS 1891.1

- The sternal point is suitable for use with rope or cable grabs.
- Ideally positioned sit-strap for extended comfort.
- Lateral D-Rings: For attachment with pole straps, to enable the worker to work comfortably, with both hands free.
- Padded Belt: Increases support and worker productivity.
- The standard harness is a one-size-fits-most covering M - XXL.

SUITABLE FOR: Positioning Restraint, Confined space rescue, construction & maintenance, warehouse, roofing work, Tower Work, elevated platforms and Suspension.



Spec sheet available on the website



1. Dorsal D-ring: Made of Aluminium Alloy.

2. Frontal D-rings: Made of Aluminium Alloy.

3. Lateral D-rings: Made of Aluminium Alloy. Made of aluminium alloy. Designed with a bend to stand out enables easy attachment.

4. Fall arrest & Confine Space Shoulder Loops

5. Tool holding loops with Protective Cover

6. Padded Shoulder Strap: Fully padded with knitted mesh for better comfort and air circulation. Equipped with silver reflective tap.

7. Work Positioning Belt: Fully padded with mesh pads for better comfort and air circulation. Equipped with aluminium adjustable buckles.

8. Padded Thigh Strap: The distinctively placed fully padded straps with Quick release buckles allows easy adjustment. The knitted mesh net used in the pads maintains proper air circulation.

9. Adjustable Buckle: Provided with pulling grip strap to easily adjust straps for a good lift.

10. Quick Release Buckle: Extremely easy to use with single-hand. Made of aluminium alloy.

11. Triple Action Karabiner: Light weight and easy to use. Made of aluminium alloy.

12. Adjustable Seat Configuration Strap: Specially designed and provided with pulling grip strap to easily adjust straps to meet all purposes and provide better support than others.



Premium Range Standard Features	
13. Product Label:	Product label with protection sleeve.
14. Polyester webbing:	44mm width and designed with superior webbing to buckle relationship, effortlessly slides through the buckle for easy adjustment.
15. Elastic Loops:	Designed to retain the excess strap while adjustment.
16. Adjustable shoulder Strap:	Equipped with elastic loops to enable the user to bring shoulder strap in required position.
17. Adjustable Thigh Strap:	Equipped with elastic loops to enable the user to bring thigh strap in required position.
18. Adjustable Waist Strap:	Equipped with elastic loops to enable the user to bring waist strap in required position.
19. Dorsal Attachment Point:	For attachment for fall arrest, enables straight upright position in the event of a fall.
20. Frontal Attachment Points:	For attachment for fall arrest, enables easy connection in the event of a fall.
21. Lateral Attachment Points:	For attachment for work positioning, designed with a bend to stand out for easy attachment.

MaxiPro Tower Harness

CODE: 915013

The MaxiPro Tower Harness is an innovative design allowing the user full adjustment of the chest, legs and position of the Dorsal D-Ring that fits more users, more comfortably.

Believe that webbing to adjustment relationship is critical to happy users, as well as the ease of putting on the harness. With this in mind we designed the MaxiPro Tower to be what the workforce is looking for.

In the event of a fall, the durable polyester webbing distributes the impact evenly over the thighs, torso and buttock region. Polyester is known for being wear resistant and non-stretch when compared to other materials, so the harness does not stretch dangerously out of shape when subjected to a fall, therefore the wearer does not risk slipping out of the harness.

- The sternal point is suitable for use with rope or cable grabs.
- Ideally positioned sit-strap for extended comfort.
- Lateral D-Rings: For attachment with pole straps, to enable the worker to work comfortably, with both hands free.
- Padded Belt: Increases support and worker productivity.
- The standard harness is a one-size-fits-most covering M - XXL.

SUITABLE FOR: Positioning Restraint, Confined space rescue, construction & maintenance, warehouse, roofing work, Tower Work, elevated platforms and Suspension.



1. Dorsal D-ring: Made of aluminium. Designed with a bend to stand out for easy attachment.

2. Extension Strap: Incorporated on the dorsal D-ring and has a loop on the end. It allows easy rescue and minimizes the discomfort while being rescued and allows user to easily connect to or disengage from dorsal attachment point without external help. The extension strap lies on the harness webbing with the help of Velcro.

3. Frontal D-rings: Made of Aluminium Alloy.

4. Lateral O-rings: Made of Aluminium Alloy. Designed to enable easy pole strap attachment.

5. Fall Arrest & Confine Space Shoulder Loops

6. Chest Padding: Fully padded with knitted mesh for better comfort and air circulation.

7. Work Positioning Belt: Fully padded with mesh pads for better comfort and air circulation. Equipped with aluminium adjustable buckles.

8. Adjustable Padded Seat Strap: The fully padded strap is equipped with quick release buckles allows easy adjustment and designed for maintains proper air circulation.

9. Adjustable Buckle: Provided with pulling grip strap to easily adjust straps for a good lift.

10. Quick Release Buckle: Extremely easy to use with single-hand. Made of aluminium alloy.

11. Seat Configuration Strap: Specially designed to meet all purposes and provide better support.



Premium Range Standard Features	
12. Polyester webbing:	44mm width and designed with superior webbing to buckle relationship, effortlessly slides through the buckle for easy adjustment.
13. Elastic Loops:	Designed to retain the excess strap while adjustment.
14. Adjustable Front & Back Strap:	Equipped with rear buckle for adjustment of back webbing ring to allow comfort use for different heights.
15. Adjustable Thigh Strap:	Equipped with elastic loops to enable the user to bring thigh strap in required position.
16. Adjustable Waist Strap:	Equipped with elastic loops to enable the user to bring waist strap in required position.
17. Dorsal Attachment Point:	For attachment for fall arrest, enables straight upright position in the event of a fall.
18. Frontal Attachment Points:	For attachment for fall arrest, enables easy connection in the event of a fall.
19. Lateral Attachment Points:	For attachment for work positioning, designed with a bend to stand out for easy attachment.

Fall Protection Equipment

MaxiPro Riggers Harness

CODE: 915014

The MaxiPro Riggers Harness is an innovative design allowing the user full adjustment of the chest, legs and position of the Dorsal D-Ring that fits more users, more comfortably.

Believe that webbing to adjustment relationship is critical to happy users, as well as the ease of putting on the harness. With this in mind we designed the MaxiPro Tower to be what the workforce is looking for.

In the event of a fall, the durable polyester webbing distributes the impact evenly over the thighs, torso and buttock region. Polyester is known for being wear resistant and non-stretch when compared to other materials, so the harness does not stretch dangerously out of shape when subjected to a fall, therefore the wearer does not risk slipping out of the harness.

- The sternal point is suitable for use with rope or cable grabs.
- Ideally positioned sit-strap for extended comfort.
- Lateral D-Rings: For attachment with pole straps, to enable the worker to work comfortably, with both hands free.
- Padded Belt: Increases support and worker productivity.
- The standard harness is a one-size-fits-most covering M - XXL.

SUITABLE FOR: Positioning Restraint, Confined space rescue, construction & maintenance, warehouse, roofing work, Tower Work, elevated platforms and Suspension.



1. Dorsal D-ring: Made of aluminium. Designed with a bend to stand out for easy attachment.

2. Extension Strap: Incorporated on the dorsal D-ring and has a loop on the end. It allows easy rescue and minimizes the discomfort while being rescued and allows user to easily connect to or disengage from dorsal attachment point without external help. The extension strap lies on the harness webbing with the help of Velcro.

3. Frontal D-rings: Made of Aluminium Alloy.

4. Lateral D-ring: Made of aluminium. Designed with a bend to stand out for easy attachment.

5. Fall Arrest & Confine Space Shoulder Loops

6. Chest Padding: Fully padded with knitted mesh for better comfort and air circulation.

7. Work Positioning Belt: Fully padded with mesh pads for better comfort and air circulation. Equipped with aluminium adjustable buckles.

8. Total Restraint D-rings: Made of Aluminium Alloy.

9. Tool Holding Loops with Protective Cover

10. Padded Seat Strap: Fully padded straps with knitted mesh maintains proper air circulation.

11. Adjustable Buckle: Provided with pulling grip strap to easily adjust straps for a good lift.

12. Quick Release Buckle: Extremely easy to use with single-hand. Made of aluminium alloy.

13. Seat Configuration Strap: Specially designed to meet all purposes and provide better support.



Premium Range Standard Features	
14. Polyester webbing:	44mm width and designed with superior webbing to buckle relationship, effortlessly slides through the buckle for easy adjustment.
15. Elastic Loops:	Designed to retain the excess strap while adjustment.
16. Adjustable Front & Back Strap:	Equipped with rear buckle for adjustment of back webbing ring to allow comfort use for different heights.
17. Adjustable Thigh Strap:	Equipped with elastic loops to enable the user to bring thigh strap in required position.
18. Adjustable Waist Strap:	Equipped with elastic loops to enable the user to bring waist strap in required position.
19. Dorsal Attachment Point:	For attachment for fall arrest, enables straight upright position in the event of a fall.
20. Frontal Attachment Points:	For attachment for fall arrest, enables easy connection in the event of a fall.
21. Lateral Attachment Points:	For attachment for work positioning, designed with a bend to stand out for easy attachment.

Tool Lanyards

Austlift Tool Lanyards range meet the ANSI / ISEA 121 standard and are designed to securely attach to tools to help prevent dangerous drops while providing the user with freedom of mobility and unimpeded functionality of the tool.

Webbing Tool Connector with D Ring



CODE	LENGTH (mm)	WIDTH (mm)	SWL (kg)
916901	60	20	1

Webbing Tool Connector with D Ring



CODE	LENGTH (mm)	WIDTH (mm)	SWL (kg)
916902	115	20	1

Webbing Tool Connector with D Ring



CODE	LENGTH (mm)	WIDTH (mm)	SWL (kg)
916903	140	20	2

Webbing Tool Connector with Swivel Head



CODE	LENGTH (mm)	WIDTH (mm)	SWL (kg)
916906	115	20	1

Elastic Webbing Tool Attachment with Swivel Head



CODE	LENGTH (mm)	SWL (kg)
916910	270	10

Elastic Tool Lanyard Swivel Snap Hook & Non Swivel Snap Hook



CODE	LENGTH (mm)	SWL (kg)
916912	900	12.5

Elastic Tool Lanyard Swivel Snap Hook & Draw String



CODE	LENGTH (mm)	SWL (kg)
916914	900	12.5

Elastic Tool Lanyard Heavy Duty with Snap Hook & Webbing Loop



CODE	LENGTH (mm)	SWL (kg)
916918	1100	18

Elastic Tool Lanyard Extra Heavy Duty with Snap Hook & Webbing Loop



CODE	LENGTH (mm)	SWL (kg)
916920	1900	36

Tool Attachment V-Ring Anchor Dual Arm



CODE	LENGTH (mm)	SWL (kg)
916907	640	16

Wire Sling Tool Connector with Metal Crimping



CODE	LENGTH (mm)	SWL (kg)
916908	155	1

Spring Tool Lanyard with Snap Hooks



CODE	LENGTH Min.-Max. (mm)	SWL (kg)
916922	48-150	2

Measuring Tape Holder



CODE	SWL (kg)
916930	1

Battery Holder



CODE	SWL (kg)
916932	4

Adjustable Wrist Band Tool Holder



CODE	SWL (kg)
916940	2.2

Self-merging Rubber Tape



CODE	LENGTH	WIDTH
916909	3.65M	25.4mm

Fall Protection Equipment

Lanyards

Each Lanyard offers you distinct features. Choose the Lanyard that best suits your requirement

WEBBING LANYARDS (44mm)



- Austlift offers a wide range of webbing lanyards made from high tenacity polyester yarn having a different configuration of connectors on the ends.
- The loops at the ends are protected by an abrasion resistant covering. This prevents the webbing from being damaged by the metallic contact of the connector.
- Available in lengths of 1.8M.
- Certified product and complies to AS/NZS 1891 and has a minimum breaking strength of 22kN.
- This webbing lanyard in this section is made up of 44mm wide polyester webbing.
- UV stable weas per AS/NZS 1891.

KERNMANTLE ROPE LANYARDS (12mm)

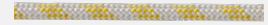

- This range of lanyard is made from high quality kernmantle rope of 12mm dia.
- They are cross stitched and are protected with a strong transparent covering sleeve. This not only protects the end, but also makes the stitches visible for easy inspection prior to use.
- The loops at the end are protected by an abrasion restraint thimble. This prevents the rope from being damaged by the metallic contact of the connectors.
- Available in lengths of 1.8M.
- Certified product and complies to AS 1891 and has a minimum breaking strength of 22kN.
- Kernmantle energy absorbing lanyards are considerably resistant to collection of grime and dust.
- The sheath of the rope protects the inner core and provides much better longevity through the line.

ENERGY ABSORBER



How does the Energy Absorber Work?

In the event of a fall the special webbing inside the energy absorber opens up. This opening of the webbing takes up most of the shock which is felt as an impact when a fall occurs. Thus reducing the impact of force on the body of the worker to below 6kN as per AS/NZS 1891 Standards.

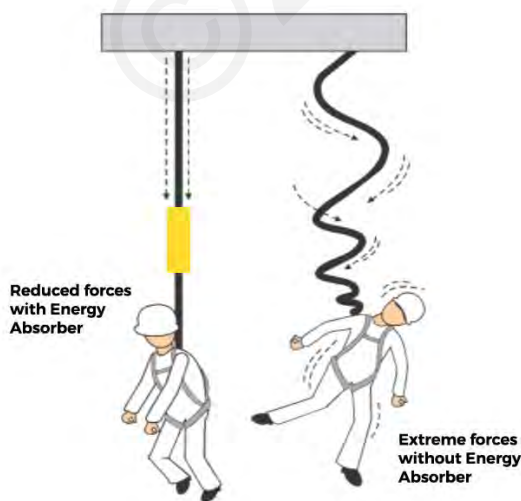

ELASTICATED LANYARDS



- These lanyards are ideal for use in conditions where there are chances of the user tripping over the lanyard. The elastic nature of the lanyard reduces its actual effective length thereby reducing trip hazards.
- Certified product and complies to AS 1891.1 and has a minimum breaking strength of 22kN.
- UV stable webbing as per AS/NZS 1891.

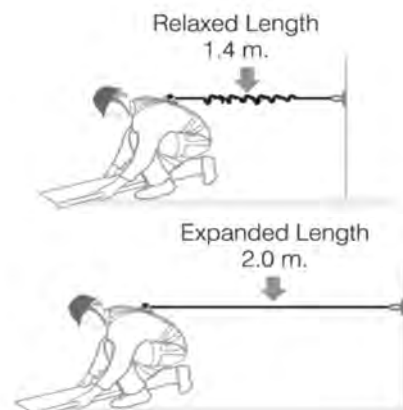

Single Webbing Lanyard

Made of high tensile polyester yarn having alloy steel snap hooks at the end. The loops at the ends are protected by an abrasion resistant covering. This prevents the webbing from being damaged by the metallic contact of the connector. Spec sheet available on the website.

SUITABLE FOR: Rear dee attachment, construction & maintenance, warehouse, roofing work and elevated work platforms.

Single Webbing Lanyard (with Snap Hooks)



- 2M long x 44mm wide polyester webbing.
- Maximum free Fall: 2M.
- Two alloy steel double action snap hooks: 20mm gate opening, 23 kN minimum breaking strength.
- Integral energy shock absorber.
- Certified product and complies to AS 1891.5.

Single Elasticated Lanyard (with Snap Hooks)



- 44mm wide tubular webbing.
- Relaxed Length: 1.4-1.6M. Expanded Length: 2M.
- Maximum free Fall: 2M.
- Two alloy steel double action snap hooks: 20mm gate opening, 23 kN minimum breaking strength.
- Integral energy shock absorber.
- Certified product and complies to AS 1891.5.

Single Adjustable Lanyard (with Snap Hook & Scaffold Hook)



- 2M long x 44mm wide polyester webbing.
- Maximum free Fall: 2M.
- Alloy steel double action snap hook: 20mm gate opening, 23kN minimum breaking strength.
- Alloy steel scaffold hook: 60mm gate opening, 23 kN MBS.
- Alloy steel roller buckle: 15 kN MBS.
- Plastic adjustment webbing keeper.
- Integral energy shock absorber.
- Certified product and complies to AS 1891.5.

Single Elasticated Lanyard (with Triple Action Hook & Scaffold Hook)



- 44mm wide tubular webbing.
- Relaxed Length: 1.4-1.6M. Expanded Length: 2M.
- Maximum free Fall: 2M.
- Alloy steel triple action hook: 20mm gate opening, 23kN minimum breaking strength.
- Alloy steel scaffold hook: 60mm gate opening, 23 kN MBS.
- Integral energy shock absorber.
- Certified product and complies to AS 1891.5.

Single Webbing Lanyard (with Triple Action Hooks)



- 2M long x 44mm wide polyester webbing.
- Maximum free Fall: 2M.
- Two alloy steel triple action hooks: 20mm gate opening, 23 kN minimum breaking strength.
- Integral energy shock absorber.
- Certified product and complies to AS 1891.5.
- Certified to 140kg.

Single Elasticated Lanyard (with Triple Action Hooks)



- 44mm wide tubular webbing.
- Relaxed Length: 1.4-1.6M. Expanded Length: 2M
- Maximum free Fall: 2M.
- Integral energy shock absorber.
- Two alloy steel triple action hooks: 20mm gate opening, 23kN minimum breaking strength.
- Certified product and complies to AS 1891.5.
- Certified to 140kg.

Fall Protection Equipment

Single Webbing Lanyard

Made of high tensile polyester yarn having alloy steel snap hooks at the end. The loops at the ends are protected by an abrasion resistant covering. This prevents the webbing from being damaged by the metallic contact of the connector. Spec sheet available on the website.

SUITABLE FOR: Rear dee attachment, construction & maintenance, warehouse, roofing work and elevated work platforms.

Single Adjustable Lanyard (with Triple Action Hooks)

CODE: 916110

- 2M long x 44mm wide polyester webbing.
- Maximum free Fall: 2M.
- Two alloy steel triple action hooks: 20mm gate opening, 23 kN minimum breaking strength.
- Alloy steel roller buckle: 15 kN MBS.
- Plastic adjustment webbing keeper.
- Integral energy shock absorber.
- Certified product and complies to AS 1891.5.
- Certified to 140kg.



Double Webbing Lanyard

Double webbing lanyards offer the facility to move in all directions while remaining safely anchored at all times, and are also subjected to the special 3-point testing to make the lanyards extra safe for use. It provides 100% tie-off required during progressive movement from one anchor point to the next, upwards or side-ways. Spec sheet available on the website.

SUITABLE FOR: Rear dee attachment, construction & maintenance, ladder work, scaffolding, warehouse, roofing work and elevated work platforms.

Double Webbing Lanyard (with Snap Hook & Scaffold Hooks)

CODE: 916122

- 2M long x 44mm wide polyester webbing.
- Maximum free Fall: 2M.
- Integral energy shock absorber.
- One alloy steel double action snap hook: 20mm gate opening, 23 kN minimum breaking strength.
- Two alloy steel scaffold hooks: 60mm gate opening, 23 kN MBS.
- Certified product and complies to AS 1891.5.



Double Adjustable Lanyard (with Snap Hook & Scaffold Hooks)

CODE: 916126

- 2M long x 44mm wide polyester webbing.
- Maximum free Fall: 2M.
- Integral energy shock absorber.
- One alloy steel double action snap hook: 20mm gate opening, 23 kN minimum breaking strength.
- Two alloy steel scaffold hooks: 60mm gate opening, 23 kN MBS.
- Two alloy steel roller buckles: 15 kN MBS.
- Plastic adjustment webbing keeper.
- Certified product and complies to AS 1891.5.





Double Webbing Lanyard (with Triple Action Hooks)

CODE: 916120

- 2M long x 44mm wide polyester webbing.
- Maximum free Fall: 2M.
- Integral energy shock absorber.
- Three alloy steel triple action hooks: 20mm gate opening, 23 kN minimum breaking strength.
- Certified product and complies to AS 1891.5.
- Certified to 140kg.



Double Adjustable Lanyard (with Triple Action Hooks)

CODE: 916121

- 44mm wide tubular webbing.
- Relaxed Length: 1.4-1.6M. Expanded Length: 2M.
- Maximum free Fall: 2M.
- Integral energy shock absorber.
- Three alloy steel triple action hooks: 20mm gate opening, 23 kN minimum breaking strength.
- Certified product and complies to AS 1891.5.
- Certified to 140kg.



Double Elasticated Lanyard (with Triple Action Hooks & Scaffold Hooks)

CODE: 916123

- 44mm wide tubular webbing.
- Relaxed Length: 1.4-1.6M. Expanded Length: 2M
- Maximum free Fall: 2M.
- Integral energy shock absorber.
- One alloy steel triple action hook: 20mm gate opening, 23kN minimum breaking strength.
- Two alloy steel scaffold hooks: 60mm gate opening, 23 kN MBS.
- Certified product and complies to AS 1891.5.
- Certified to 140kg.

Energy Absorber with Double Action Karabiners

CODE: 916130

The energy absorber is equipped with steel quarter turn locking karabiners on each end and consists of a special white inner polyamide webbing which absorbs the arresting forces in the event of a fall. It limits the impact of a fall to less than 6kN. The coloured webbing serves as a backup. The clear protective covering helps in easy and fast visual inspection.



SUITABLE FOR: Rear dee, frontal attachment, restraint construction & maintenance, warehouse and roofing work.

- 44mm wide polyester webbing.
- Two steel quarter turn locking karabiners: 17mm gate opening, 23 kN minimum breaking strength.
- Maximum free fall: 2M.
- Certified product and complies to AS 1891.5.

Single Sharp Edge Rope Lanyard

Made from sharp edge resistant kernmantle rope of 12mm diameter. The loops at the end are protected by an abrasion resistant thimble which prevents the rope from being damaged by the metallic contact of the connector. Adjustable lanyards are equipped with rope grabs for an easy adjustment. Spec sheets available on the website.

SUITABLE FOR: Rear dee attachment, construction & maintenance, scaffolding, warehouse, roofing work and elevated work platforms.

Single Sharpe Edge Rope Lanyard (with Snap Hooks)



CODE: 916201

- 2M long x 12mm diameter kernmantle rope with sharpe edge resistance.
- Maximum free Fall: 2M.
- Integral energy shock absorber.
- Two alloy steel double action snap hooks: 20mm gate opening, 23 kN minimum breaking strength.
- Certified product and complies to AS 1891.5.

Single Sharpe Edge Rope Lanyard (with Triple Action Hooks)



CODE: 916204

- 2M long x 12mm diameter kernmantle rope with sharpe edge resistance.
- Maximum free Fall: 2M.
- Integral energy shock absorber.
- Two alloy steel triple action hooks: 20mm gate opening, 23 kN minimum breaking strength.
- Certified product and complies to AS 1891.5.

Single Sharpe Edge Adjustable Lanyard (with Triple Action Hooks)



CODE: 916228

- 2M long x 12mm diameter kernmantle rope with sharpe edge resistance.
- Maximum free Fall: 2M.
- Integral energy shock absorber.
- Alloy steel triple action hook: 20mm gate opening, 23kN minimum breaking strength.
- Alloy steel rope grab: 15 kN MBS.
- Alloy steel triple action hook with capital pin: 16.5mm gate opening, 23kN MBS.
- Certified product and complies to AS 1891.5.

Single Sharpe Edge Adjustable Lanyard (with Triple Action Hook & Scaffold Hooks)



CODE: 916231

- 2M long x 12mm diameter kernmantle rope with sharpe edge resistance.
- Maximum free Fall: 2M.
- Integral energy shock absorber.
- Alloy steel triple action hook: 20mm gate opening, 23kN minimum breaking strength.
- Alloy steel rope grab: 15 kN MBS.
- G80 steel connector: 23kN MBS.
- Alloy scaffold hook: 60mm gate opening, 23 kN minimum breaking strength.
- Certified product and complies to AS 1891.5.

Double Sharp Edge Rope Lanyard

Made from sharp edge resistant kernmantle rope of 12mm diameter. The loops at the end are protected by an abrasion resistant thimble which prevents the rope from being damaged by the metallic contact of the connector. Adjustable lanyards are equipped with rope grabs for an easy adjustment.

SUITABLE FOR: Rear dee attachment, construction & maintenance, scaffolding, warehouse, roofing work and elevated work platforms.

Double Sharpe Edge Rope Lanyard (with Snap Hooks & Scaffold Hooks)



60 - 140kg



CODE: 916212

- 2M long x 12mm diameter kernmantle rope with sharpe edge resistance.
- Maximum free Fall: 2M.
- Integral energy shock absorber.
- One alloy steel double action snap hook: 20mm gate opening, 23kN minimum breaking strength.
- Two alloy steel scaffold hooks: 60mm gate opening, 23 kN MBS.
- Certified product and complies to AS 1891.5.

Double Sharpe Edge Rope Lanyard (with Triple Action Hooks)



60 - 140kg



CODE: 916209

- 2M long x 12mm diameter kernmantle rope with sharpe edge resistance.
- Maximum free Fall: 2M.
- Integral energy shock absorber.
- Three alloy steel triple action hooks: 20mm gate opening, 23kN minimum breaking strength.
- Certified product and complies to AS 1891.5.

Double Sharpe Edge Adjustable Lanyard (with Triple Action Hooks)



60 - 140kg



CODE: 916229

- 2M long x 12mm diameter kernmantle rope with sharpe edge resistance.
- Maximum free Fall: 2M.
- Integral energy shock absorber.
- One alloy steel triple action hook: 20mm gate opening, 23kN minimum breaking strength.
- Two alloy steel rope grabs: 15 kN MBS.
- Two alloy steel triple action hooks with capital pin: 16.5mm gate opening, 23 kN MBS.
- Certified product and complies to AS 1891.5.

Double Sharpe Edge Adjustable Lanyard (with Triple Action Hook & Scaffold Hooks)



60 - 140kg



CODE: 916230

- 2M long x 12mm diameter kernmantle rope with sharpe edge resistance.
- Maximum free Fall: 2M.
- Integral energy shock absorber.
- One aluminum alloy triple action hook: 20mm gate opening, 23 kN minimum breaking strength.
- Two alloy scaffold hooks: 60mm gate opening, 23 kN MBS.
- Two alloy rope adjusters: 15kN MBS, black anodized finish.
- Two oval delta links.
- Certified product and complies to AS 1891.5.

Double Sharpe Edge Adjustable Lanyard (with Triple Action Hook & Scaffold Hooks)

CODE: 916232

- 2M long x 12mm diameter kernmantle rope with sharpe edge resistance.
- Maximum free Fall: 2M.
- Integral energy shock absorber.
- One alloy triple action hook: 20mm gate opening, 23 kN minimum breaking strength.
- Alloy steel rope grab: 15 kN MBS.
- G80 steel connector: 23kN MBS.
- Two alloy scaffold hooks: 60mm gate opening, 23 kN minimum breaking strength.
- Certified product and complies to AS 1891.5.



Double Sharpe Edge Adjustable Lanyard (with Aluminum Alloy Triple Action Hook & Scaffold Hooks)

CODE: 916233

- 2M long x 12mm diameter kernmantle rope with sharpe edge resistance.
- Maximum free Fall: 2M.
- Integral energy shock absorber.
- One aluminum alloy triple action hook: 20mm gate opening, 23 kN minimum breaking strength.
- Two alloy rope adjusters: 15kN MBS, black anodized finish.
- G80 steel connector: 23kN MBS.
- Two aluminum alloy scaffold hooks: 60mm gate opening, 23 kN minimum breaking strength.
- Certified product and complies to AS 1891.5.



Double Sharpe Edge Adjustable Lanyard (with Aluminum Alloy Triple Action Hooks)

CODE: 916234

- 2M long x 12mm diameter kernmantle rope with sharpe edge resistance.
- Maximum free Fall: 2M.
- Integral energy shock absorber.
- Three aluminum alloy triple action hooks: 20mm gate opening, 23 kN minimum breaking strength.
- Two alloy rope adjusters: 15kN MBS, black anodized finish.
- G80 steel connector: 23kN MBS.
- Certified product and complies to AS 1891.5.



Fall protection Equipment

Hot Works Webbing Lanyard & Pole Strap

Hot works webbing lanyards are designed to offer the perfect solution for safe working at height in potentially explosive atmosphere. The Antistatic components of these lanyards prevent the risk of an electrostatic build up and sudden discharge, igniting the explosive atmosphere. Special Repellent Webbing: It's oil, dirt and water repellent hence provides excellent resistance from build up of oil and dirt. Highly tear and cut resistant because does not allow abrasion due to collection of dust or dirt. Highly UV resistant webbing. Easy maintenance wipes clean in seconds. Spec sheets available on the website.

Single Hot Works Webbing Lanyard (with Snap Hooks)



CODE: 916140

- 2M x 44 mm wide Flame Resistant webbing.
- Maximum free Fall: 2M.
- Integral energy shock absorber.
- Covered by a special flame resistant tubular pouch.
- Two alloy steel double action snap hooks: 20mm gate opening, 23 kN minimum breaking strength.
- Certified product and complies to AS 1891.5.

SUITABLE FOR: Rear dee attachment, construction & maintenance, warehouse, roofing work and elevated work platforms.

Hot Works Single Webbing Lanyard (with Snap Hook & Scaffold Hook)



CODE: 916141

- 2M x 44 mm wide Flame Resistant webbing.
- Maximum free Fall: 2M.
- Covered by a special flame resistant tubular pouch.
- Alloy steel double action snap hook: 20mm gate opening, 23kN minimum breaking strength.
- Alloy steel scaffold hook: 60mm gate opening, 23 kN MBS.
- Integral energy shock absorber.
- Certified product and complies to AS 1891.5.

SUITABLE FOR: Rear dee attachment, construction & maintenance, warehouse, roofing work and elevated work platforms.

Hot Works Pole Strap (with Snap Hooks)



CODE: 916143

- 44 mm wide Flame Resistant webbing.
- Adjustable length: 1M to 2.5M.
- Alloy steel double action snap hooks: 20mm gate opening, 23 kN minimum breaking strength on both ends.
- Certified product and complies to AS 1891.5.

SUITABLE FOR: Work positioning restraint. (Full body harness side D-ring attachment as a work positioning belt)

Hot Works Double Webbing Lanyard (with Snap Hook & Scaffold Hooks)



CODE: 916142

- 2M x 44 mm wide Flame Resistant webbing.
- Maximum free Fall: 2M.
- Covered by a special flame resistant tubular pouch.
- One alloy steel double action snap hook: 20mm gate opening, 23kN minimum breaking strength.
- Two alloy steel scaffold hooks: 60mm gate opening, 23 kN MBS.
- Integral energy shock absorber.
- Certified product and complies to AS 1891.5.

SUITABLE FOR: Rear dee attachment, construction & maintenance, warehouse, roofing work and elevated work platforms.

Webbing Pole Strap

CODE: 916241

This webbing pole strap is fully adjustable, allowing for various work positioning applications, such as line and pole top work to support a worker on a pole or tower. Equipped with buckle for length adjustment. Equipped with 60cm long protective covering webbing.

SUITABLE FOR: Work positioning restraint - Full body harness side D-ring attachment as a work positioning belt.

- 44mm wide heavy duty polyester webbing.
- Adjustable length: 1M to 2.5M.
- Two alloy steel double action snap hooks: 20mm gate opening, 23 kN minimum breaking strength.
- Integral wear sleeve.
- Certified product and complies to AS 1891.5.



Kernmantle Rope Pole Strap

CODE: 916240

The combination of AS/NZS approved Kernmantle rope and rope grab allows the user to quickly adjust the length of the strap on the fly. Designed with steel double action snap hook on one side and stitched loop on the other side. It is equipped with Aluminium Rope grab which has a steel triple action karabiner attached. Polyester protective sleeve protects kernmantle adjusting fitting from damage and displace.

SUITABLE FOR: Rear dee attachment, construction & maintenance, scaffolding, warehouse, roofing work and elevated work platforms.

- 12mm diameter kernmantle rope.
- Adjustable length: 1M to 2.5M.
- Polyester protective sleeve.
- Alloy steel double action snap hooks: 20mm gate opening, 23 kN minimum breaking strength.
- Alloy steel triple action hooks: 20mm gate opening, 23 kN minimum breaking strength.
- Aluminium alloy rope grab.
- Certified product and complies to AS 1891.5.



Suspension Trauma Strap

CODE: 915075

Suspension Trauma Straps are designed to avoid the effect of Suspension Trauma. Compact and light weight without hampering the activity of the worker. Allows the suspended worker to stand up in their harness to relieve pressure after falling. Easy to attach to the Harness and easy to deploy.

Preventing suspension intolerance

To prevent suspension intolerance occurring as a result of an arrested fall, you should ensure that where the rescue is likely to take more than five minutes the harness and connection point used should allow the suspended worker to raise their legs to near horizontal, or the worker should carry straps to provide footholds





Steel Adjustable Lanyard

In this system, the rope grab is constructed of high strength steel and works on 12mm diameter kernmantle rope anchorage line, incorporated permanently on the anchorage line, and comes with an energy absorbing element.

It is not detachable from the rope and this gives an advantage that the worker does not lose the device when the equipment is not in use. This system is an ideal fall restraint device for use while working on platforms and roofs. The anchorage line has one side loop for connector and the other side a stop knot.

- 12mm diameter kernmantle rope.
- Available in 5M, 15M, 20M and 25M.
- Steel rope grab: 15kN minimum breaking strength.
- Steel quarter turn locking karabiner with safety pin: 17mm gate opening, 23kN minimum breaking strength.
- Steel triple-action locking karabiner with safety pin: 21.5mm gate opening, 40kN minimum breaking strength.
- Conforms to AS 1891.5 & EN 353-2:2002.
- Spec sheet available on the website.

SUITABLE FOR: Use in Fall Restraint applications particularly whilst working on platforms and roof tops

5M CODE: 916305

15M CODE: 915840

20M CODE: 915841

25M CODE: 915842



Spreader Bar **CODE: 915700**

AUSTLIFT spreader bar is designed to be used in conjunction with the harness for raising and lowering during rescue. The attached webbing loops can be used to secure victim's arm when lifting or lowering. Certified to AS/NZS 1891.1. Consist of steel snap hooks and alloy steel d-ring.

- D Ring for attachment to Retrieval Block.
- 44mm Polyester Webbing.
- Adjustable buckles.
- Wrist loops to secure casualties arms.
- Snap hooks each side to attach to Harness rescue shoulder loops.
- Alloy steel snap hooks: Meets ANSI Z359.12-2009, 16kN gate strength, 20mm gate opening, 23 kN minimum breaking strength on both ends.
- Spec sheet available on the website.



Alloy Adjustable Lanyard

In this system, the rope grab is constructed of high strength aluminium alloy and works on 12mm diameter kernmantle rope anchorage line, incorporated permanently on the anchorage line, and comes with an energy absorbing element.

It is not detachable from the rope and this gives an advantage that the worker does not lose the device when the equipment is not in use. This system is an ideal fall restraint device for use while working on platforms and roofs. The anchorage line has one side loop for connector and the other side a stop knot.

- 12mm diameter kernmantle rope.
- Available in 15M, 20M, 25M and 30M.
- Aluminium alloy rope grab: 15kN minimum breaking strength.
- Steel quarter turn locking karabiner with safety pin: 17mm gate opening, 23kN minimum breaking strength.
- Steel triple-action locking karabiner with safety pin: 21.5mm gate opening, 40kN minimum breaking strength.
- Conforms to AS 1891.5 & EN 353-2:2002.
- Spec sheet available on the website.

SUITABLE FOR: Use in Fall Restraint applications particularly whilst working on platforms and roof tops

15M CODE: 916315

20M CODE: 916320

30M CODE: 916330



Endless Anchor Sling

- Made of high tensile polyester
- Width: 20mm
- Rated Load: 15kN
- Conforms to AS/NZS 5532:2013

1M CODE: 915026

1.5M CODE: 915024

2M CODE: 915021



Inertia Reels

Wire Rope Inertia Reel Series

Casing made of high impact strength polymer to prevent breakage and is nearly indestructible. Comes in galvanized steel wire rope of diameter 4.5mm. Swivel triple action locking snap hook with fall indicator at the bottom and triple action Karabiner on top. Anchorage eye with swivel action. Prevents undue twist of rope while working or in the event of a fall.

- Rope diameter: 4.5mm.
- Rope material: Steel.
- Minimum breaking strength: 12kN.
- Rated for 140kg.
- The steel triple-action locking swivel hook: 21mm gate opening, 23kN minimum breaking strength.
- The steel triple-action locking karabiner: 22mm gate opening, 25kN minimum breaking strength.
- Conformity: AS 1891.3 & EN 360:2002.



7M Wire Rope Inertia Reel (Sharp Edge Tested)

CODE: 915207

- Rated for: 140kg
- Max. Length: 7M
- Weight: 3.79kg

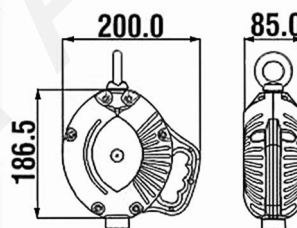

10M Wire Rope Inertia Reel (Sharp Edge Tested)

CODE: 915210

- Rated for: 140kg
- Max. Length: 10M
- Weight: 6kg

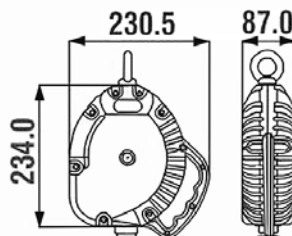

Fall Protection Equipment

20M Wire Rope Inertia Reel

CODE: 915220

- Rated for: 140kg
- Max. Length: 20M
- Weight: 6.05kg

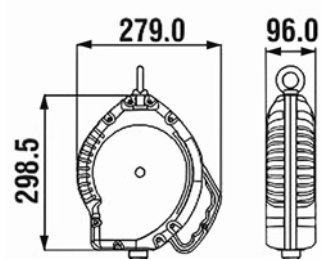

30M Wire Rope Inertia Reel

CODE: 915230

- Rated for: 140kg
- Max. Length: 30M
- Weight: 12.8kg

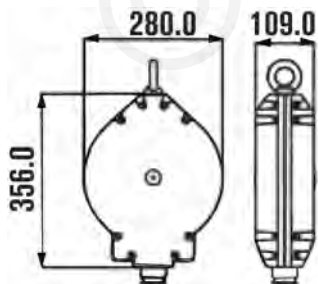

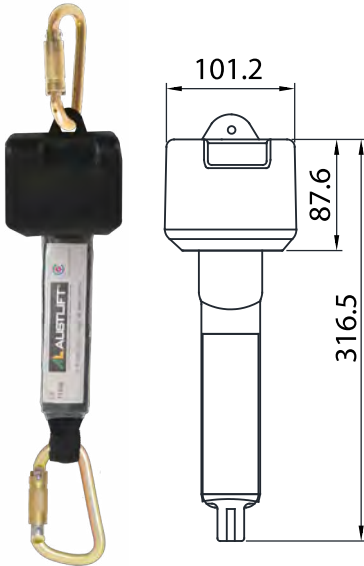

CODE: 915302

Retractable Webbing Mini Block

Retractable Mini Block is made of a protective case with 47mm webbing with a maximum length of 2.5m. It is incorporated with an energy absorber and two triple action steel Karabiners.

- Maximum length : 2.5m
- Rated Load: 140kg.
- Minimum Breaking Strength > 15kN.
- Weight : 1.20kg ± 10g.
- The alloy steel triple action karabiner: 22mm gate opening, 25kN minimum breaking strength.
- Conformity: AS 1891.3 & EN 360:2002.



CODE: 915303

Retractable Webbing Inertia Reel

Retractable webbing block is made up of retractable webbing of width 25mm. Casing made up of high impact strength polymer to prevent breakage and is nearly indestructible. Swivel eye with triple action steel karabiner at top and triple action swivel hook at bottom with fall indicator. Anchorage eye with swivel action prevents undue twist of webbing while working or in the event of a fall.

- Maximum length : 3.5M
- Rated Load: 140kg.
- Minimum Breaking Strength > 12kN.
- Weight : 1.97kg.
- The steel triple-action locking swivel hook: 21mm gate opening, 23kN minimum breaking strength.
- The steel triple-action locking karabiner: 22mm gate opening, 25kN minimum breaking strength.
- Conformity: AS 1891.3 & EN 360:2002.



Sharp Edge tested Retractable Block

The ideal position of a Retractable Block when used as a part of personal Fall Arrest System, is directly overhead, or to an anchor point that is placed above the level of the Dorsal D-Ring of the user's harness. However, while working on rooftops, beams, etc, the blocks may be required to be anchored horizontally. Not all blocks can be anchored at this level.

Austlift Sharp edge tested blocks can be used in horizontal condition, and in such conditions where the worker is exposed to a sharp edge hazard. The integrated energy absorber pack helps to reduce the impact of forces of the cable, as it comes in contact with the sharp edge. Each block in this range is constructed in such a way that if subjected to contact with a sharp edge in the event of a fall from a roof/Terrace etc, the retracted lanyard remains intact, while arresting the fall immediately. These blocks are equipped with an external energy absorber (with protective cover) which reduces the dynamic load impact felt on the user in the event of a fall, to less than 6kN even when the lifeline is fully drawn.

Conforms for the vertical usage as per EN 360:2003 and Horizontal usage as per V11 RFU#11.060.



Retractable Webbing Inertia Reel (Sharp Edge Tested)

Extremely light weight of 983g with inbuilt textile shock pack and removable protective cover. Casing made of robust and durable polymer. Can be used for horizontal and foot level anchorage (passes test for fall factor two). Comes with Steel Quarter Turn Locking Hook or Aluminium Scaffolding Hook.



* Twin SRL connector 915600 required when inertia reel needs to be used as a twin lanyard.



- Max. Length: 2M
- Weight: 1.31kg
- Rated Load: 140kg Vertical
- Rated Load: 100kg Horizontal and foot level
- Over edge rated.
- Minimum Breaking Strength > 15kN.
- The aluminium alloy rebar hook: 60mm gate opening, 23kN minimum breaking strength.
- Conformity: EN 360:2002, VG11 #11.060 & AS1891.3.
- Spec sheet available on the website.



- Max. Length: 2M
- Weight: 983g
- Rated Load: 140kg Vertical
- Rated Load: 100kg horizontal and foot level
- Over edge rated.
- Minimum Breaking Strength > 15kN.
- The alloy steel Quarter Turn locking hook: 20mm gate opening, 25kN minimum breaking strength.
- Conformity: EN 360:2002, VG11 #11.060 & AS1891.3.
- Spec sheet available on the website.

Wire Rope Inertia Retrival Reel Series

Wire rope inertia recovery reel with polymer casing with carry handle. Swivel eye with triple action steel karabiner at top. Triple action swivel hook bottom with fall indicator. These blocks allow the fall to arrest and also allow easy hoist of the victim with the help of their inbuilt winch mechanism when mounted on davit system and tripod. The locking pin on the side of the casing at the base of the handle allows this dual system to work in independent fall arrest & winch modes.

The dual mode helps easy movement while working in confined spaces. Retractable/Inertia mode enables easy movement of user while working in confined space whilst providing fall protection. Winch mode enables easy retrieval or rescue of the casualty post fall arrest.

- Wire rope: 4.5mm diameter steel wire rope.
- Minimum breaking strength: 12kN.
- Rated for 140kg.
- The steel triple-action locking swivel hook: 21mm gate opening, 23kN minimum breaking strength.
- The steel triple-action locking karabiner: 22mm gate opening, 25kN minimum breaking strength.
- Easily mounted on the leg of tripod and davit System by using specialised brackets.
- Conforms to AS 1891.3, EN 360:2002 & EN 1496:2006 Class B.

20M Wire Rope Inertia Retrival Reel

CODE: 915320

- Rated for: 140kg
- Max. Length: 20M
- Weight: 9.2kg



DIMENSIONS

AUSSLIFT WINCH APPLICATION

CODE	SUITABLE FOR	BRACKET
915320	915400	Cantilever Davit System
	915507	Double Pulley Tripod 7ft
	915510	Double Pulley Tripod 10ft

30M Wire Rope Inertia Retrieval Reel

CODE: 915321

- Rated for: 140kg
- Max. Length: 30M
- Weight: 14.5kg



DIMENSIONS

AUSSLIFT WINCH APPLICATION

CODE	SUITABLE FOR	BRACKET
915400	Cantilever Davit System	915416
915321	915507 Double Pulley Tripod 7ft	915512
915510	Double Pulley Tripod 10ft	915512

How to switch mode:

The locking pin on the side of the casing at the base of the handle allows this dual system to work in independent fall arrest & winch modes.

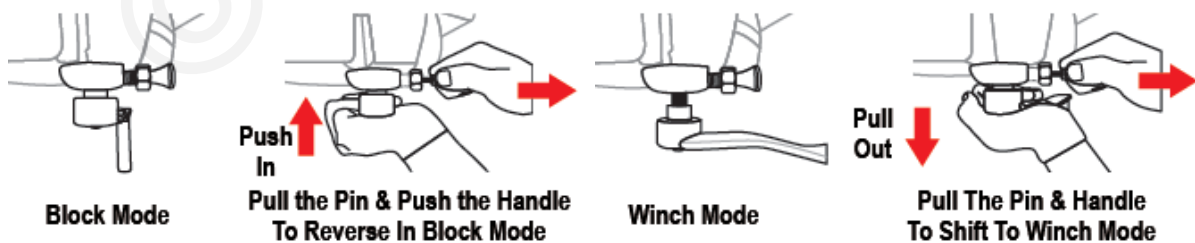

Velcro on the handle of the block:

- For safe transportation
- Keeps the handle in place.
- The handle is deployed only when winch functionality is activated.



Confined Space Entry

AUSTLIFT Tripod

For access into confined spaces. With two mounted pulleys at the head of the tripod in the prolongation of the main leg for passing a cable through. Having two auxiliary eye bolts as attachment points.

With aluminium alloy cast head and aluminium telescopic legs that are fully adjustable. Steel support shoes provided with rubber soles to increase friction and impart more stability. Strength of anchorage point greater than 12 kN.

Every tripod is provided with tripod bag. The double pulley tripod is provided with inbuilt fixture for attaching our winch PC.915508. AUSTLIFT tripod can also be used with retrieval fall arrester blocks PC.915320, PC.915321 with the help of their specialised mounting brackets respectively. Conforms to AS/NZS 5532:2013.



* Note: Sold Separately, not included in Davit system.

NEW Tripod Double Pulley Series

- Double Pulley Option
- Permanently incorporated in the cast aluminum head.
- Provides independent passing over of cable from a winch and a retrieval block.
- Also Available for wheel option. Size 7ft & 10ft.
- Spec sheet available on the website.

915507 (7ft)
915510 (10ft)



TECHNICAL SPECIFICATION (7FT)

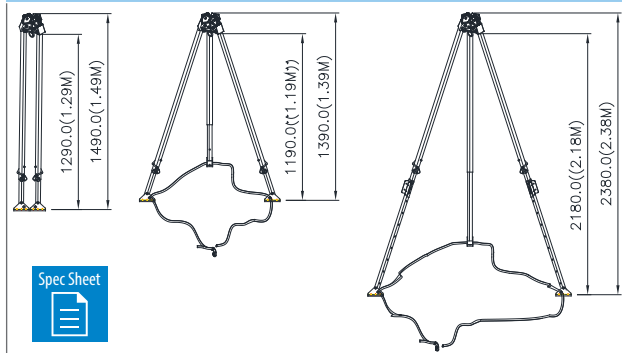

PRODUCT CODE	915507
LENGTH	7ft
WEIGHT	12.25kg
MAX. LOAD CAPACITY	500kg
BASE (DIAMETER)	1.8M
HEIGHT	1.15-2.15M

TECHNICAL SPECIFICATION (10FT)

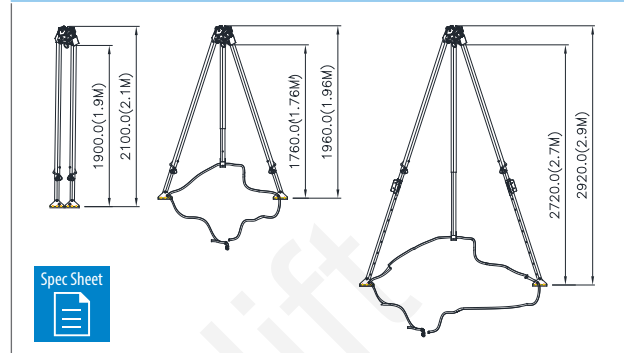

PRODUCT CODE	915510
LENGTH	10ft
WEIGHT	19.6kg
MAX. LOAD CAPACITY	500kg
BASE (DIAMETER)	2.4M
HEIGHT	1.9-3.07M

CODE: 915511



* Winch can be installed for easy retrieval & arresting the fall of user using specialised mounting brackets.

CODE: 915512



* Retrieval fall arrester block can be installed for easy retrieval & arresting the fall of user using specialised mounting brackets.

AUSSLIFT WINCH APPLICATION

7FT TRIPOD	SUITABLE FOR		BRACKET	10FT TRIPOD	SUITABLE FOR		BRACKET
915507	915508	Winch for Double Pulley Tripod	915511	915510	915508	Winch for Double Pulley Tripod	915411
	915320	Retrieval fall arrester block 20M	915512		915320	Retrieval fall arrester block 20M	915512
	915321	Retrieval fall arrester block 30M			915321	Retrieval fall arrester block 30M	

Tripod Wheel Option

- Wheel Parts
- Designed with locking feature for stability permanently installed on the Tripod shoes.
- Suitable for all series Tripod.

915513



Fall protection Equipment

AUSTLIFT Cantilever Davit System

AUSTLIFT introduces the cantilever davit system which provides a safe and sure system for easy access to confined spaces. The davit system is an ideal choice to provide overhead anchorage which can be mounted on different bases. The davit system is made of highly corrosion resistant G316 stainless steel, and can swivel a complete 360° on its mounted base, hence providing versatile reach and access.

The unique feature is that the height of the cantilever arm of the davit system is adjustable at 3 defined points, with upper height adjustment of 2.3M, middle

arm adjustment of 1.9M, and lowered arm adjustment at 1.5M. This enables the use of the davit system even in those areas where the roof height is low.

The davit system can be easily mounted on the floor as well as on the wall through special floor and wall mounting brackets which are made available as per requirement. The davit system can also be mounted on the floor of heavy vehicles, hence making it extremely versatile in use.

Conforms to AS/NZS 5532:2013.

Spec sheet available on the website.



CODE: 915400

VITAL TEST COMPLIANCE

- Static strength: 15kN for 3min.
- Dynamic strength: fall with 100kg, it should be stable and hold clear from the ground.
- Integrity test: after dynamic strength sustained 300kg, mass for 3 min.

PHYSICAL PARAMETERS:

- Made up of highly corrosion resistant G316 stainless steel.
- Two eye bolts (stainless steel) at cantilever arm for anchor points.
- Max. Load capacity: 136kg for rescue.
- Finish: polished.
- Arm strength: 300kg for material use.

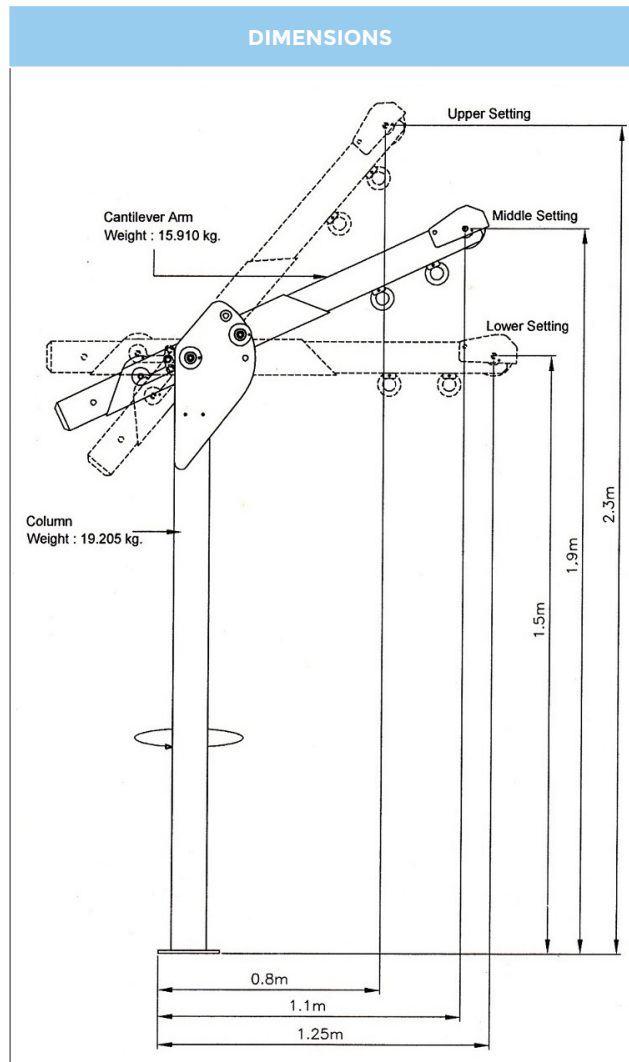

SETTING	DISTANCE FROM BAR	HEIGHT OF ARM
Upper	0.8M	2.3M
Middle	1.1M	1.9M
Lower	1.25M	1.5M

Fall Protection Equipment

- AUSTLIFT winch PC. 915408 can be easily mounted on to the davit system with the help of G316 stainless steel fasteners.
- Retrieval fall arrester block PC.915320 and PC.915321 can also be installed for easy retrieval & arresting the fall of the user using the specialised mounting brackets: PC.915412, PC.915416

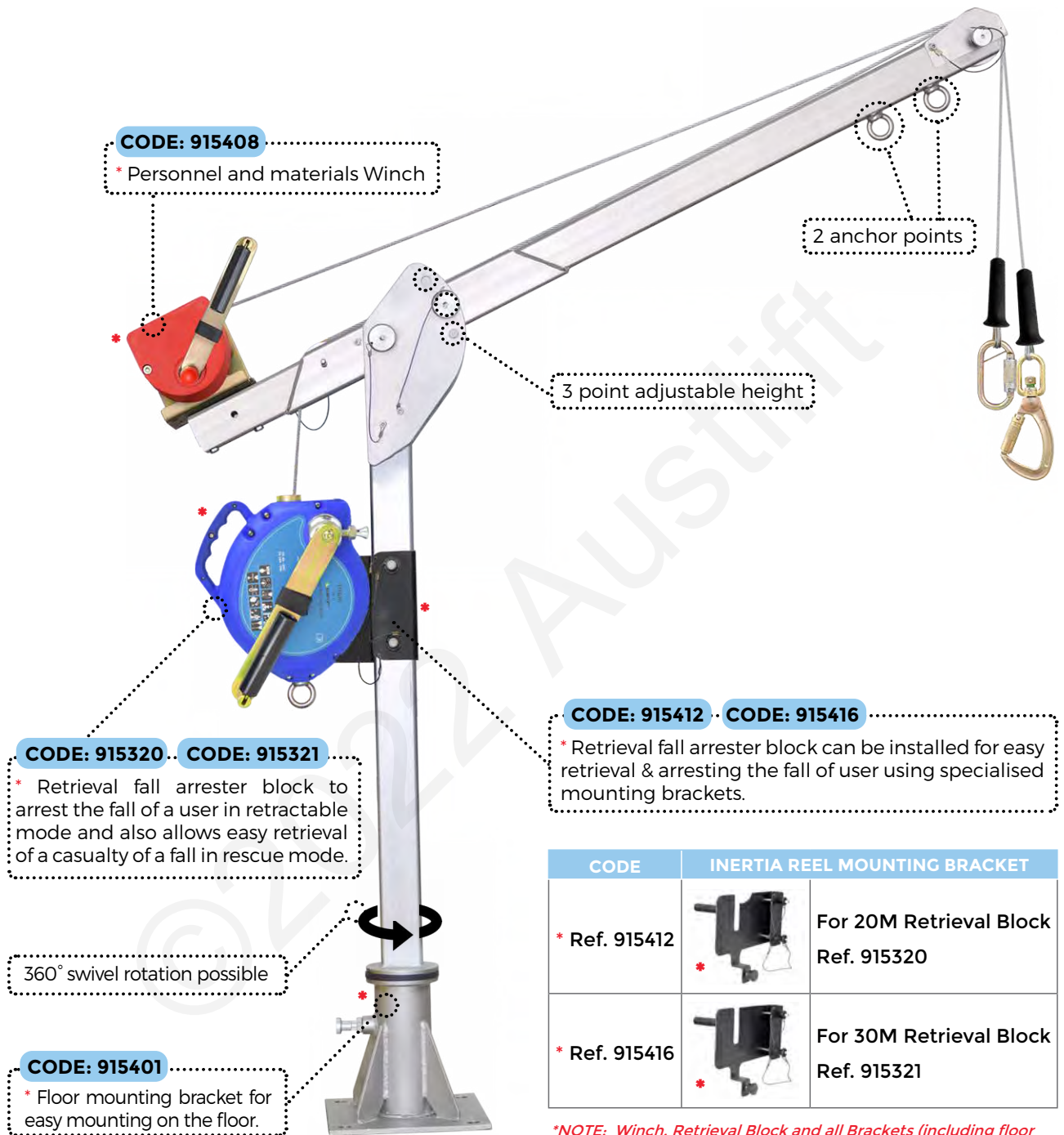

**NOTE: Winch, Retrieval Block and all Brackets (including floor mount) not included in Davit Arm and Mast.*

CODE	FLOOR MOUNTING BRACKET		CODE	WALL MOUNTING BRACKET	
* Ref. 915401			* Ref. 915402		
NET WEIGHT			NET WEIGHT		
11.825kg			12.850kg		



Compact Cantilever Davit System CODE: 915420

AUSTLIFT Compact Davit system has been designed for confined space entry / retrieval applications. Its modular interchangeable design allows the system to be mounted on multiple bases for all applications. It is ideal for providing portable, safe overhead anchorage in large confined areas like manholes, storage tanks.

- The Extreme H-Base Davit breaks down into five components for easy storage, transport and set-up. No tools are required for assembly.
- The modular design allows the use of various fixed and portable bases and an optional mast with extensions.

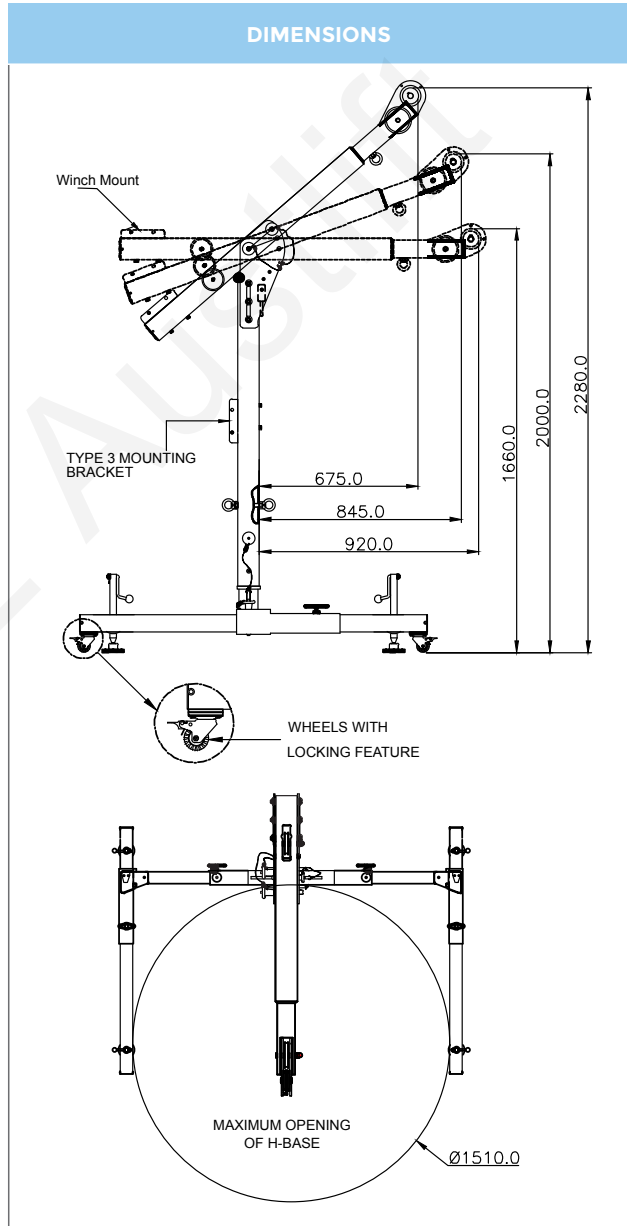
- Cantilever arm comes with 3 adjustment positions for the user to adjust the height as per the requirement.
- An ideal choice to provide overhead anchorages in large holes of confined space.
- Removable legs for easy transportation and installation purpose.
- Anchorage points for rescue applications.
- Foldable legs for easy transportation and installation purpose.
- Multi anchorage point for rescue purpose.
- Inbuilt swivel feature, Davit column assembly can be rotated upto 360° by removing the locking.
- Conforms to AS/NZS 5532:2013.



CODE	BRACKET USED FOR MOUNTING	
Ref. 915511		For Winch Ref. 915508
Ref. 915512		For Retrieval Block Ref. 915320, 915321
TECHNICAL SNAPSHOT		
Material	High Strength and Durable Aluminium Alloy	
Min. & Max. Opening of H Base	Ø1100 mm - Ø 1510 mm	
Maximum Load Capacity	500 kgs	
Finish	ED Coated	
System Strength	15kN	
Weight	62.56kgs ± 0.10kgs	

SETTING	DISTANCE FROM BAR	HEIGHT OF ARM
Upper	0.675M	2.28M
Middle	0.845M	2.0M
Lower	0.92M	1.66M

Fall Protection Equipment

Winch **CODE: 915408**

AUSSLIFT winch is designed to be used for raising or lowering of personnel or material into confined spaces. Can be mounted on the Tripod and standard Davit system with the help of their universal mounting brackets respectively. Consist of double action locking karabiner as a connector.

- Winch cable: galvanised steel wire rope of diameter 4.8mm, 20M long.
- Maximum lifting load capacity as per EN 1496 : 135 kg.
- Maximum lifting load capacity as per machine directive 2006/42/EC : 250 kg.
- The alloy steel double action locking karabiner: 17mm gate opening, 23kN minimum breaking strength.
- Conforms to : EN 1496:2017 (Class A)

AUSSLIFT WINCH APPLICATION			
CODE	SUITABLE FOR		BRACKET
915408	915400	Davit Standard	Not required
	915507	Tripod 7ft	 915511
	915510	Tripod 10ft	



Winch **CODE: 915508**

AUSSLIFT winch is designed to be used for raising or lowering of personnel or material into confined spaces. Comes with pre-installed mounting plate compatible with the mounting bracket fixed on the leg of the Tripod and compact Davit system. Consist of double action locking karabiner as a connector.

- Winch cable: galvanized steel wire rope of diameter 4.8mm, 20M long.
- Maximum lifting load capacity as per EN 1496 : 135 kg.
- Maximum lifting load capacity as per machine directive 2006/42/EC : 250 kg.
- The alloy steel double action locking karabiner: 17mm gate opening, 23kN minimum breaking strength.
- Conforms to : EN 1496:2017 (Class A)
- Spec sheet available on the website.

AUSSLIFT WINCH APPLICATION			
CODE	SUITABLE FOR		BRACKET
915508	915420	Davit Compact	Not required
	915507	Tripod 7ft	
	915510	Tripod 10ft	



Winch **CODE: 915509**

AUSSLIFT winch is designed to be used for raising or lowering of personnel or material into confined spaces. Comes with pre-installed mounting plate compatible with the mounting bracket fixed on the leg of the Tripod and compact Davit system. Consist of steel swivel snap hook as a connector.

- Winch cable: galvanised steel wire rope of diameter 6mm, up to 40M long.
- Maximum lifting load capacity as per EN 1496 : 135 kg.
- Maximum lifting load capacity as per machine directive 2006/42/EC : 250 kg.
- The alloy steel swivel snap hook: 20mm gate opening, 23kN minimum breaking strength.
- Conforms to : EN 1496:2017 (Class A)

AUSSLIFT WINCH APPLICATION			
CODE	SUITABLE FOR		BRACKET
915509	915420	Davit Compact	Not required
	915507	Tripod 7ft	
	915510	Tripod 10ft	



Height Safety Kits









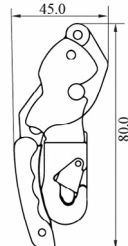

AUSTLIFT Rescue Kit CODE: 915110

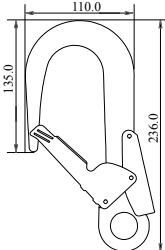
AUSTLIFT rescue kit is specifically designed for rescuing a suspended casualty from fall arrest lanyards, rope safety lines & fall arrest blocks, all possible from a point of safety.

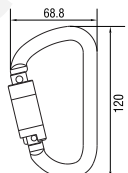
The kit comes complete with steel karabiners, aluminium rebar hook, kernmantle rope, aluminium double pulleys, grip descender, anchorage webbing slings & a dry bag with shoulder straps for easy carrying. The kit is provided with a 2.4M telescopic pole for extension to the fall victim, and hence does not require the rescuer to descend to the victim. Conforms to all relevant CE norms.

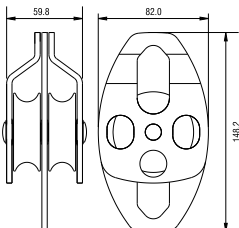

Fall Protection Equipment

COMPONENTS	QTY	IMAGE	
<p>Grip Descender Jumper</p> <ul style="list-style-type: none"> Material: aluminium alloy Works on 10.5mm to 12mm diameter kernmantle rope Finish: coloured anodized Net weight: 440g ± 20g Conformity: EN 341 Class B, EN 12841 Type C 	x1		
<p>Rebar Hook CODE: 916826</p> <ul style="list-style-type: none"> Material: high strength aluminium alloy Gate opening: 60mm Minimum breaking strength: 23kN Finish: natural silver Net weight: 445g Conformity: EN 362:2004 Class T Process: forged 	x1		
<p>Quarter Turn-Locking Karabiner</p> <ul style="list-style-type: none"> Material: alloy steel Gate opening: 21mm Minimum breaking strength: 40kN Finish: galvanized with golden Net weight: 264 ± 10g Conformity: EN 362:2004 Class B 	x3		
<p>Double Side pulley CODE: 915609</p> <ul style="list-style-type: none"> Material: aluminium alloy Minimum breaking strength: 36kN Finish: polished & anodized Net weight: 770 ± 20g Conformity: EN 12278:2007 	x2		
<p>Telescopic Pole CODE: 915835</p> <ul style="list-style-type: none"> Material : fiber aluminium Net weight: 900g Length: 1.2M-2.4M 	x1		
<p>Cross Arm Strap CODE: 915083</p> <ul style="list-style-type: none"> 44mm wide and 1.2M long polyester webbing D-ring at one end and textile loop at the other end Strength: min 18 kN for 3 minutes Conforms to AS/NZS 5532:2013 	x2		
<p>Kernmantle Rope (50M) CODE: 915750</p> <ul style="list-style-type: none"> Made of polyester kernmantle rope Diameter: 12 mm. One side loop; other side end stop knot. Length: 50M 	x1		
<p>Rescue Bag</p> <ul style="list-style-type: none"> High quality waterproof dry bag 	x1		

Fall protection
Equipment



Rescue Ladder System

CODE: 915430

AUSTLIFT rescue ladder system is designed to rescue the casualty from fall. Comprehensive system for easy access at height. Consists of light weight ladder weighing about 1920g±10g & has a minimum breaking strength of 20kN.

The ladder of 6 metres, included in the system allows a victim to climb safely while the rescuer pulls rope slack through the rope grab included in the system eliminating the chance of a high impact secondary fall.

This webbing rescue ladder is made of 20mm polyester webbing having a diameter of 11mm aluminium rod rungs. Length of rope available: 15 metres. Comes with easy back packable carrying bag.

RESCUE LADDER	OTHER COMPONENTS	QTY	IMAGE
<p>(6M)</p>	<p>Rope Grab</p> <ul style="list-style-type: none"> Material: aluminium alloy Minimum breaking strength: 15kN Finish: anodized Net weight: 183g Conformity: EN 362:2004 Class B & Class M 	x1	
	<p>Steel Screw Locking Karabiner</p> <ul style="list-style-type: none"> Material: alloy steel Gate opening: 18mm Minimum breaking strength: 25kN Finish: gold yellow galvanized Net weight: 160.5g Conformity: EN 362:2004 Class B & Class M 	x3	
	<p>Rigging Plate</p> <ul style="list-style-type: none"> Material: aluminium alloy Minimum breaking strength: 45kN Finish: color anodized Net weight: 53.5g ± 10g Conformity: CNB/P/11.114 	x1	
	<p>Kernmantle Anchorage Line</p> <ul style="list-style-type: none"> Made of polyester kernmantle rope Diameter: 12 mm. One side loop; other side end stop knot Length: 15M 	x1	
	<p>Height Safety Anchor Sling</p> <ul style="list-style-type: none"> Made of high tensile polyester Length: 1.5M Width: 20mm Rated Load: 15kN 	x1	
	<p>Kit Bag</p> <ul style="list-style-type: none"> Polyester bag for Ladder Rescue Kit 	x1	



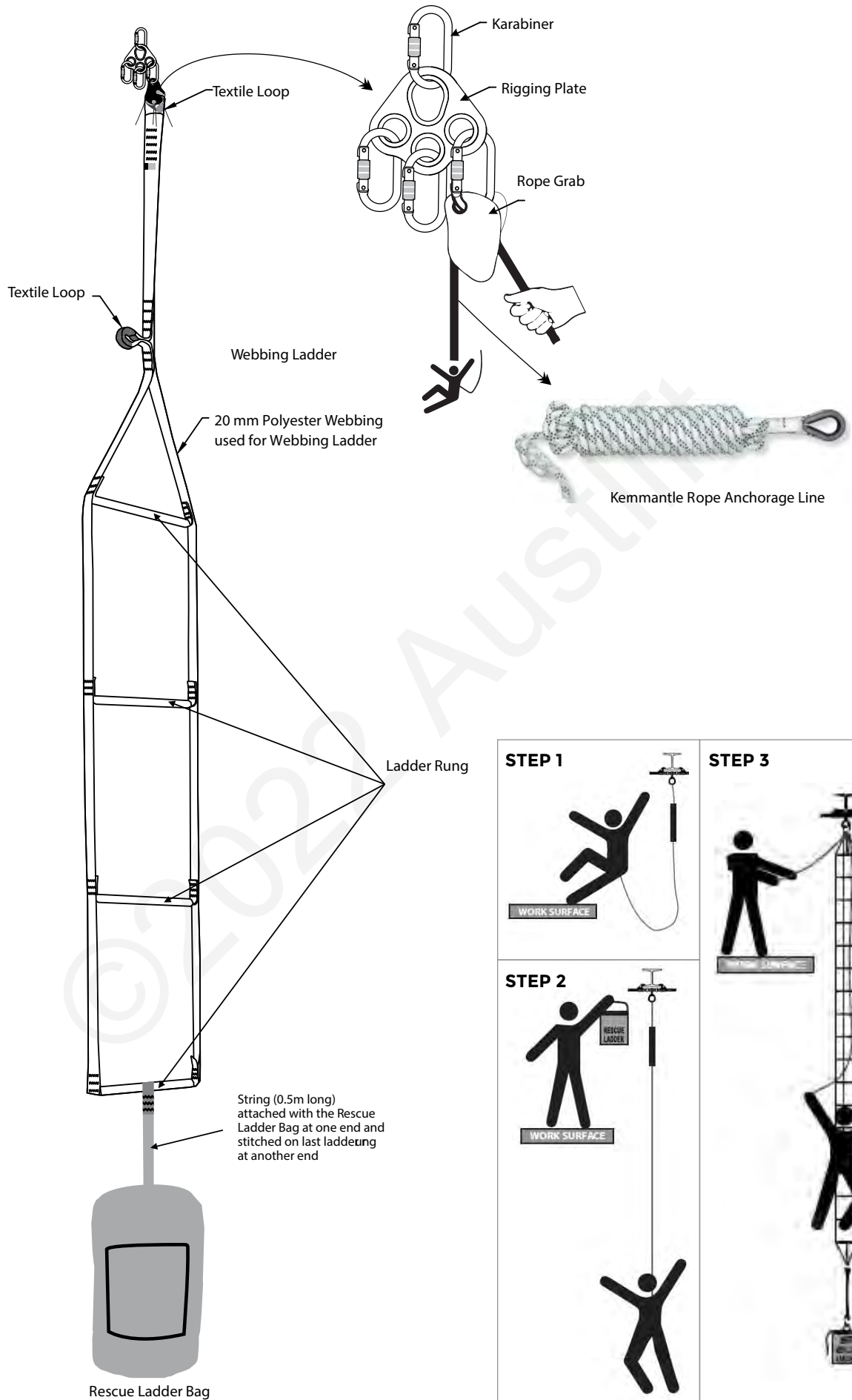

Fall Protection Equipment



Fall protection
Equipment

Roofers Kit Basic CODE: 915100

Austlift Basic Roofers kit comes complete with a Tradesman full body harness, fall arrest system and tie off anchor strap all packed in a back pack for convenience, suitable for any roofing application.

COMPONENT	QTY	IMAGE	DESCRIPTION
A = Anchor Point Anchor Sling	1		<ul style="list-style-type: none"> Material: high tensile polyester Length: 1.5M Width: 50mm Rated load: 2.45T
B = Body Support Tradesman Harness	1		<ul style="list-style-type: none"> Large upright dorsal d-ring (MBS: 23kN) Alloy steel connection and buckles (MBS: 15kN) 44mm wide polyester webbing
C = Connector Fall Arrester: 12mm x 15M kernmantle rope with rope grab and shock pack attached. Triple action karabiner one end and abrasion resistant thimble termination, stop knot on other end.	1		1. Kernmantle Rope 15M
			2. Triple Action Karabiner <ul style="list-style-type: none"> Material: alloy steel Gate opening: 21.5mm MBS: 45kN Net weight: 249g
			3. Rope Grab <ul style="list-style-type: none"> Material: Alloy Steel MBS: 15kN Net weight: 447.5g
			4. Quarter Turn-Locking Karabiner <ul style="list-style-type: none"> Material: alloy steel Gate opening: 17mm MBS: 22kN Net weight: 160.5g
			5. Shock Pack <ul style="list-style-type: none"> Width: 44mm Material: polyester webbing Maximum free fall: 2M
Backpack	1		<ul style="list-style-type: none"> 410 x 280 x 150mm Waterproof zip

Fall Protection Equipment

Roofers Kit Core

CODE: 915101

Austlift Core Roofers kit comes complete with a Tradesman full body harness, fall arrest system, a tie off anchor strap and a steel edge anchor all packed in a back pack for convenience, suitable for any roofing application.

COMPONENT	QTY
A = Anchor Point Anchor Sling	1
A = Anchor Point Flat Bar Anchor <ul style="list-style-type: none"> Material: Galvanized Steel Minimum breaking strength: 15kN Weight: 1.5kg Conformity: AS/NZS 5532:2013 	1
B = Body Support Tradesman Harness	1
C = Connector Fall Arrester: 12mm x 20M kernmantle rope with rope grab and shock pack attached. Triple action karabiner one end and abrasion resistant thimble termination, stop knot on other end.	1
Backpack	1



Roofers Kit Premium

CODE: 915102

Austlift Premium Roofers kit comes complete with a Prime Rigger full bodyharness, fall arrest system, a tie off anchor strap and a steel edge anchor all packed in a back pack for convenience, suitable for any roofing application.

COMPONENT	QTY
A = Anchor Point Anchor Sling	1
A = Anchor Point Steel Edge Anchor <ul style="list-style-type: none"> Material: Galvanized Steel Minimum breaking strength: 15kN Weight: 1.5kg Conformity: AS/NZS 5532:2013 	1
B = Body Support Prime Rigger Harness <ul style="list-style-type: none"> Large upright dorsal d-ring (MBS: 23kN) Quick Release Buckles connection Confined Space Shoulder Loops Suspension Trauma Strap included 	1
C = Connector	1
Backpack	1



Anchorage

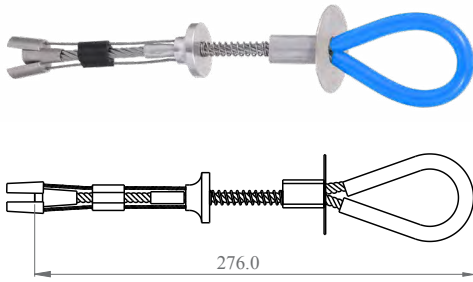

Note: A hole of diameter 18-19mm & depth 110mm needs to be drilled into the concrete to install this anchor inside.

Concrete Anchor CODE: 915150

- Material: Stainless Steel
- Minimum breaking strength: 15kN
- Net weight: 150g
- Conforms EN 795:2012 & AS/NZS 5532:2013.

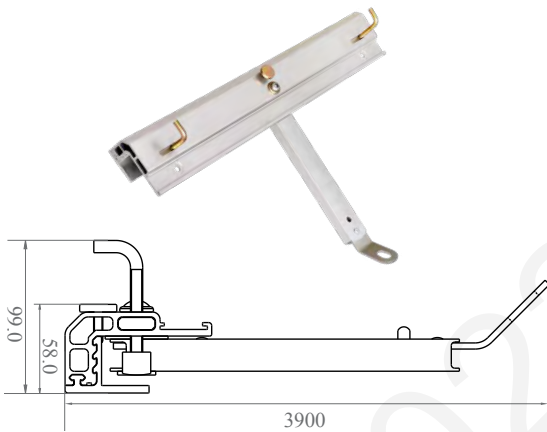

PRIME Edge Anchor CODE: 915151

- Material: Aluminium Alloy & Stainless Steel
- Minimum breaking strength: 15kN
- Net weight: 3.0kg ± 50g
- Range of Cladding Profile: up to 30mm
- Conformity: EN 795:2012 & AS/NZS 5532:2013.

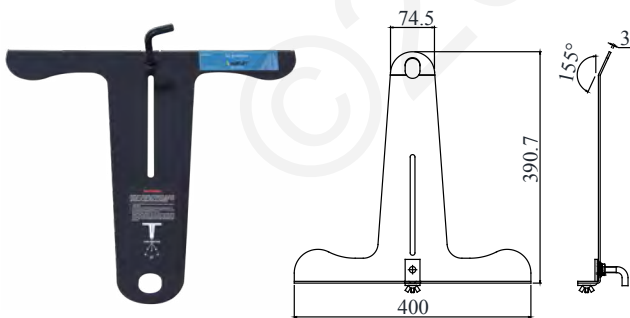

CORE Edge Anchor CODE: 915156

- The unique design of the steel edge anchor allows multi-depth adjustment to suit varying roof cladding profiles.
- Designed for the use of Single user only
- Material: Galvanized Steel
- Minimum breaking strength: 15kN
- Light weight. Weight: 1.5kg
- Conformity: AS/NZS 5532:2013

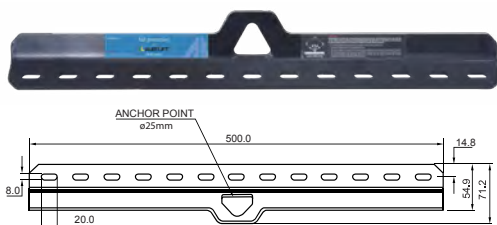

Flat Bar Anchor CODE: 915155

- The unique design of the steel edge anchor allows multi-depth adjustment to suit varying roof cladding profiles.
- Designed for the use of Single user only
- Material: Galvanized Steel
- Minimum breaking strength: 15kN
- Light weight. Weight: 1.5kg
- Conformity: AS/NZS 5532:2013

Fall Protection Equipment

Beam Anchor CODE: 915153

- Material: Aluminium Alloy & Stainless Steel
- Minimum breaking strength: 23kN
- Net weight: 2.8kg
- Flanges adjustable from: 90mm to 290mm
- Conformity: EN 795:2012 & AS/NZS 5532:2013

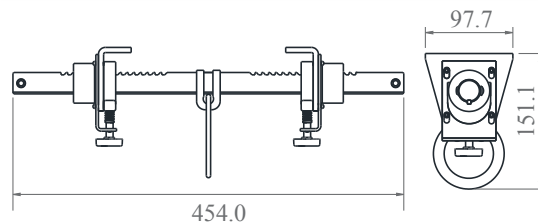

Beam Anchor CODE: 915154

- Material: Aluminium Alloy & Brass
- Minimum breaking strength: 23kN
- Net weight: 1.872kg ± 10g
- Flanges adjustable from: 90mm to 340mm
- Conformity: EN 795:2012 & AS/NZS 5532:2013

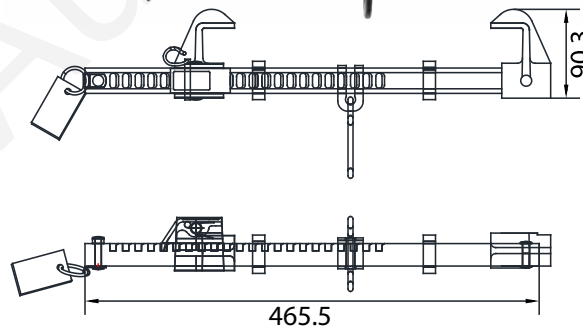

Beam Anchor Trolley CODE: 915157

- Material: Aluminium Alloy & Stainless Steel
- Minimum breaking strength: 23kN
- Net weight: 3.9kg ± 10g
- Flanges adjustable from: 80mm to 250mm
- Conformity: EN 795:2012 & AS/NZS 5532:2013

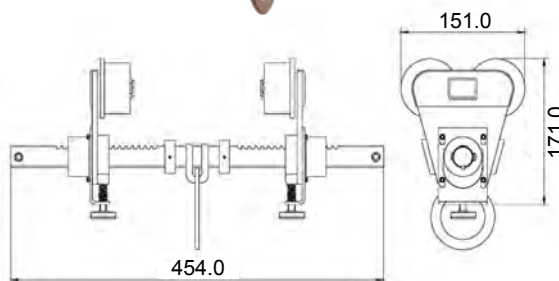

Fall protection
Equipment

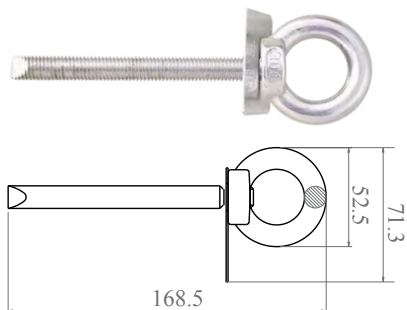

Point Anchor

CODE: 915152

- Material: Stainless Steel
- Minimum breaking strength: 23kN
- Net weight: 300g ± 10g
- Used with adhesive capsule HILTI HVU2 M12 x 110mm (Not Included)
- Drilling diameter recommended for installation is 14mm x 110mm depth
- Conformity: EN 795:2012 & AS/NZS 5532:2013.



TILELINK Anchor

An anchor point designed for use on timber rafters with tiled roof, will arrest from any direction.

For Timber Rafters

CODE: 915158

- 360° Multi-directional, enabling full rotation around the anchor.
- Five fixing points with five (5) alternate fixing rows to suit multitude of tile roof profiles.
- Install using 5 x 12 gauge (50mm) roofing screws.
- Eyelet 30mm ID.



For Steel Rafters

CODE: 915159

- 360° Multi-directional, enabling full rotation around the anchor.
- Five fixing points with three (3) alternate fixing rows to suit multitude of tile roof profiles.
- Install using 5 x 8mm Rivets (Drill Size 7.8-8.2mm Aluminium).
- Eyelet 30mm ID.



FROGLINK Anchor

CODE: 915160

A height safety anchor point for use on metal roofs where access to timber is difficult, will arrest from any direction.

- Fast simple installation.
- 316 Stainless steel construction.
- Multi-directional fall protection.
- Designed to suit all roof profiles with a single row of attachment holes for the rivets.
- Install using 7 x 8mm rivets, (Drill Size 7.8-8.2mm, 27.7mm length, 1.0-9.5mm grip range, Aluminium).
- Single person energy absorbing anchor, rated at 15kN.
- Complies with: AS/NZS 1891.4, AS/NZS 5532-2013, EN 795:2012, CEN/TS 16415:2013, ANSI Z359.18 and OSHA1926.502.



Fall Protection Equipment

TEMPLINK Anchor CODE: 915161

This temporary roof anchor point has been designed for use where an anchor is required for a temporary period of time in a location that does not need to be revisited. Can be used on a metal roof or timber rafters (tile roof).

- Templink is a patented multi-directional fall device designed to absorb energy when a fall is arrested. 316 Stainless steel construction.
- 316 Stainless steel.
- Lightweight compact unit, enabling easy manoeuvring to desired location.
- Install using 7 x 8mm rivets, (Drill Size 7.8-8.2mm, 27.7mm length, 1.0-9.5mm grip range, Aluminium).
- Single person energy absorbing anchor, rated at 15kN.
- Complies with: AS/NZS 1891.4, AS/NZS 5532-2013, EN 795:2012, CEN/TS 16415:2013, ANSI Z359.18 and OSHA1926.502.

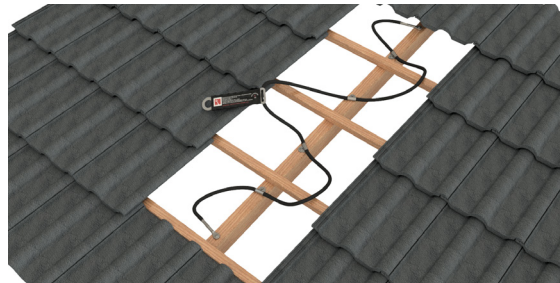

RETROLINK Anchor CODE: 915162

An abseiling anchor point designed for use on metal roofing/steel purlin structure. Installation is a simple task requiring no access from underside of the roof.

- 316 Stainless steel construction.
- Single Person Anchor.
- Multi-directional fall protection.
- Rated at 15kN.
- For use on metal roof/steel purlin structures.
- Fits to the pan of the roof sheeting.
- Anchor is energy absorbing and can be used for abseiling.
- Complies with: AS/NZS 1891.4 EN 795, CEN/TS 16415, AS/NZS 5532.
- Includes SS316 eyebolt, washer rubber and SS tube with positioning ties

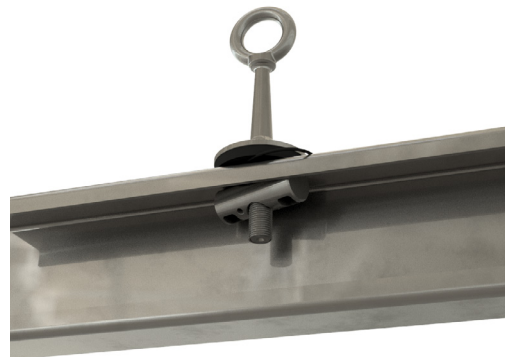

Anchor Strap CODE: 915720/915721

The interlocking and reinforced webbing anchor strap is made of 44mm wide polyester webbing and stitched with 70mm webbing at the back for extra protection. Has a small d-ring on one end & a bigger d-ring on the other.

- Working Load Limit (WLL): 21kN
- Max Number of Users: 2
- Minimum Breaking Strength (MBS): 28kN
- Certified product and complies to AS/NZS 5532.

SUITABLE FOR: Two users as an anchor strap in various configurations.



915721 0.7M



915720 1.5M



Hooks & Connectors

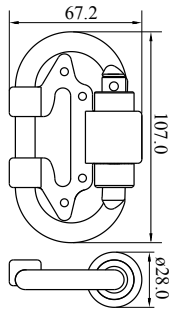

Twin SRL Connector

CODE: 915600

- Material: alloy steel & high density polyethylene
- Minimum breaking strength: 23kN
- Finish: zinc plated with yellow passivation
- Net weight: 175 ± 10g
- Conformity: EN 362:2004 Class T

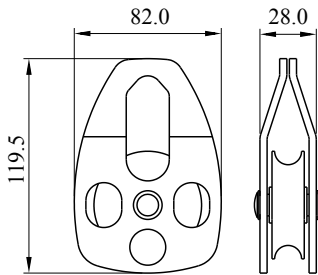

Aluminium Pulley Single Side Attachment

CODE: 915602

- Material: aluminium alloy
- Minimum breaking strength: 36 kN
- Finish: natural silver/ colored anodized
- Net weight: 234g ± 20g
- Can be used on a rope of diameter up to 16mm
- Conformity: EN 12278:2007

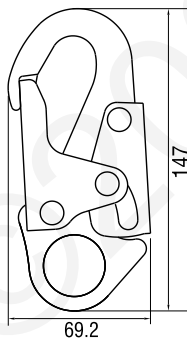

Steel Snap Hook

CODE: 916810

- Material: alloy steel
- Gate opening: 20mm
- Gate strength: 16kN
- Minimum breaking strength: 23kN
- Finish: golden yellow galvanised
- Net weight: 385g ± 10g
- Conformity: ANSI Z359.12-2009

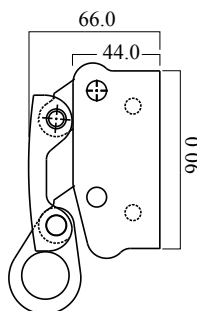

Fixed Rope Grab for Fiber Rope

CODE: 915740

- Material: alloy steel
- Minimum breaking strength: 15kN (when tested as per ANSIZ 359.1-2007)
- Finish: golden yellow galvanised
- Net weight: 447.5g
- Conforms: EN353-2:2002 & EN358:1999 within a system formed with 12mm & 14mm kernmantle rope and 16mm polyamide twisted rope

Fall Protection Equipment

Steel Quarter Turn-locking Karabiner

CODE: 916802

- Material: alloy steel
- Gate opening: 21mm
- Minimum breaking strength: 40kN
- Finish: golden yellow galvanised
- Net weight: 264g ± 10g
- Conformity: ANSI Z359.12-2009

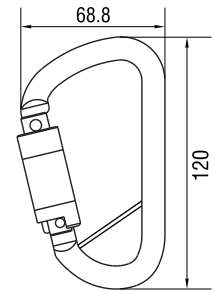

Steel Quarter Turn-locking Karabiner

CODE: 916801

- Material: alloy steel
- Gate opening: 17mm
- Minimum breaking strength: 23kN
- Finish: golden yellow galvanised
- Net weight: 160.5g
- Conformity: ANSI Z359.12-2009

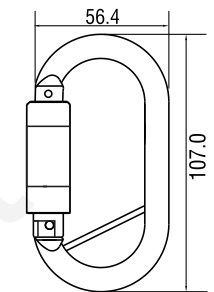

Steel Screw-locking Karabiner

CODE: 915789

- Material: alloy steel
- Gate opening: 18mm
- Minimum breaking strength: 25kN
- Finish: gold yellow galvanised
- Net weight: 160.5g
- Conformity: EN 362:2004 Class B & Class M

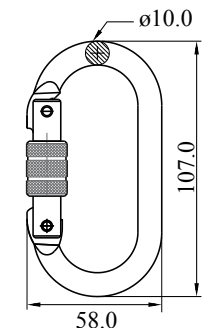

Steel Triple Action Locking Karabiner

CODE: 916803

- Material: alloy steel
- Gate opening: 21.5mm
- Minimum breaking strength: 45kN
- Finish: golden yellow galvanised
- Net weight: 249 ± 10g
- Conformity: ANSI Z359.12-2009

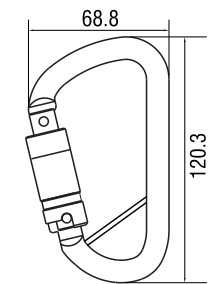

Steel Triple Action Locking Snap Hook

CODE: 916811

- Material: alloy steel
- Gate opening: 19.5mm
- Gate strength: 16kN
- Minimum breaking strength: 23kN
- Finish: golden yellow galvanised
- Net weight: 286 ± 10g
- Conformity: ANSI Z359.12-2009

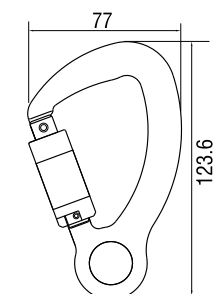

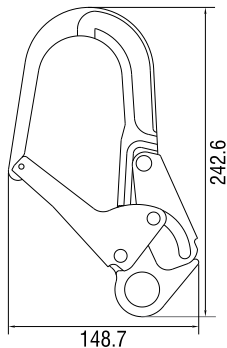

Steel Scaffold Hook

CODE: 916815

- Material: alloy steel
- Gate opening: 60mm
- Gate strength: 16kN
- Minimum breaking strength: 23kN
- Finish: golden yellow galvanised
- Net weight: 820g ± 10g
- Conformity: ANSI Z359.12-2009

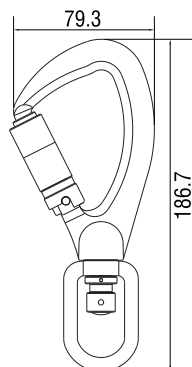

Steel Swivel Snap Triple Action Hook

CODE: 916820

- Material: alloy steel
- Gate opening: 20.4mm
- Minimum breaking strength: 23kN
- Finish: golden yellow galvanised
- Net weight: 420g ± 10g
- Conformity: ANSI Z359.12-2009

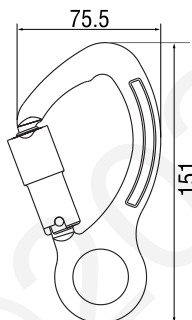

Aluminium Triple Action Locking Hook

CODE: 916821

- Material: aluminium alloy
- Gate opening: 18.4mm
- Minimum breaking strength: 23kN
- Finish: natural silver / coloured anodised
- Net weight: 153g ± 10g
- Conformity: ANSI Z359.12-2009

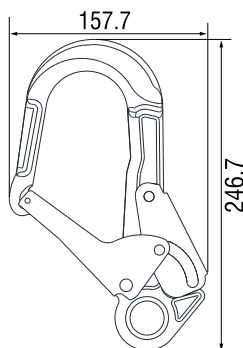

Aluminium Scaffold Hook

CODE: 916825

- Material: aluminium alloy
- Gate opening: 60mm
- Minimum breaking strength: 23kN
- Finish: natural silver / coloured anodised
- Net weight: 582g ± 10g
- Conformity: ANSI Z359.12-2009

Fall Protection Equipment

Temporary Life Line



CODE: 915130

SUITABLE FOR: Use as a temporary horizontal life line as a two person system.

Temporary Horizontal Life Line

The horizontal anchorage life line made up of 30mm polyester webbing is equipped with the ratchet tensioner that allows easy tensioning of the lifeline between two structures. Both the ends are provided with auto locking steel karabiners.

The whole system is supplied in a bag which is permanently attached and easy to carry. Once fitted, excess webbing not utilised can be put back into the bag.

Once the life line is fitted, the user can easily attach the lanyard of his harness to the lifeline using a karabiner. This allows movement along the length while keeping the user secured and safe at all times.

- 30mm wide polyester webbing.
- Total Length: 20M.
- Adjustable Length: 5-20M.
- Conforms to EN 795: 2012.
- Tested & certified for use by two users simultaneously.
- Spec sheet available on the website.

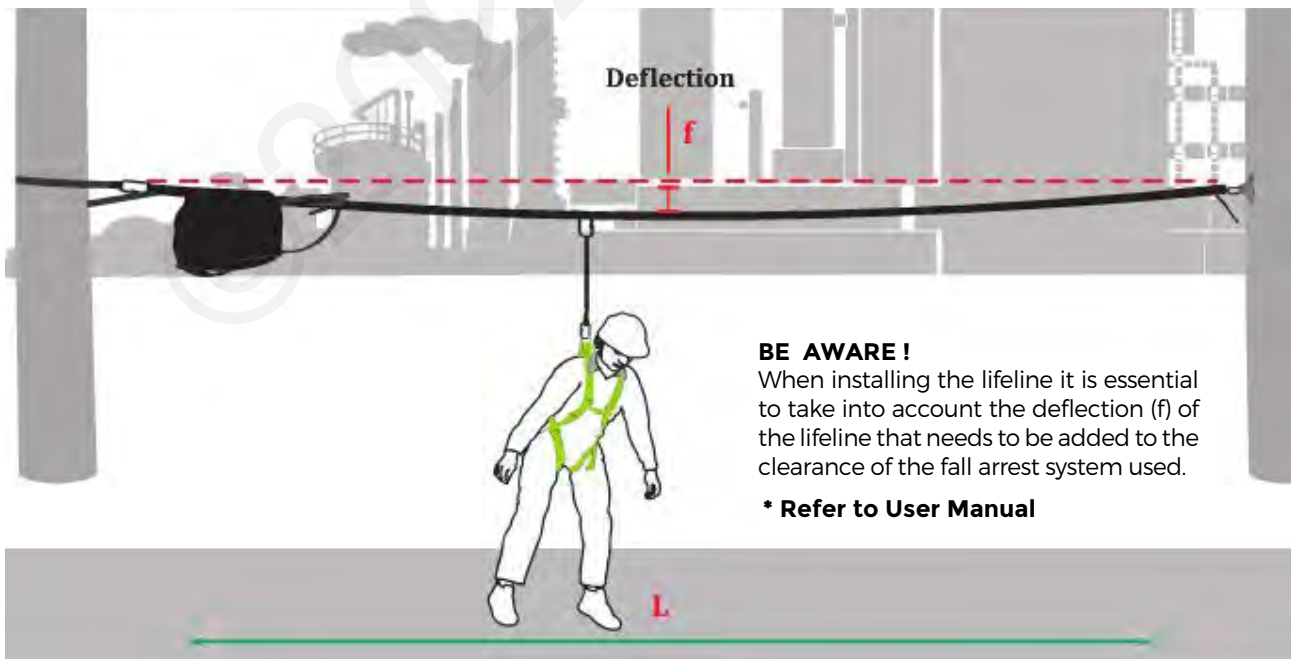

BE AWARE !
When installing the lifeline it is essential to take into account the deflection (f) of the lifeline that needs to be added to the clearance of the fall arrest system used.

*** Refer to User Manual**

Fall protection Equipment

Temporary Horizontal Rope Anchorage Line for 2 Man (Cross Over)

CODE: 915132

The new Horizon 2 man Temporary Horizontal Lifeline is another lifeline which is quick and easy to install. It is provided with a special tensioner made of Galvanized Steel that provides effortless tensioning of rope.

This Lifeline is provided with 2 'cross over anchors' made up of Stainless Steel.



FEATURES:

- Very Quick & easy to install, and is re-usable
- Suitable for upto 2 personnel
- Consist of tension indicator for creating an adequate tension in the Line
- The Lifeline made up of 16mm dia Kernmantle Rope, has a stitched loop at one end secured by a transparent protective sleeve one end. This end can be connected to rated anchor point with a help of quarter turn locking Karabiner 915820 .The other end of the lifeline is connected with the help of a Karabiner, connected to the eye of the tensioner. The anchorage line is secured at the termination with the help of a stop-knot covered with a protective sleeve.
- The system has 2 Cross Over Anchors made of Stainless Steel to allow easy crossing over between users, and prevent any disengagement from the lifeline , ensuring 100% tie off at all times
- Total Length of the Line is 25m. Covers a span of 5m to 25m
- Minimum Breaking Strength : 25kN.
- The whole system is supplied in a bag , which is permanently attached to the assembly and also enables the user to easily carry the system with the help of comfortable handles provided in the bag. This Bag is designed in such a way that it keeps the unused rope safely, thereby preventing the rope being subjected to abrasion or any damage caused from dust, dirt grin oil etc.
- Once fitted, you can easily put back the extra rope not deployed along the length, into the Bag.
- Conforms to EN 795:2012 Type C & TS 16415 : 2013 Type C

Fall Protection Equipment



Tensioner

Made of Galvanized Steel

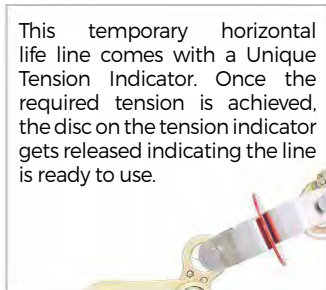

This temporary horizontal life line comes with a Unique Tension Indicator. Once the required tension is achieved, the disc on the tension indicator gets released indicating the line is ready to use.

Cross Over Anchors allow easy crossing over between users, and prevent any disengagement from the life line ensuring 100% tie off at all times.

* Karabiners shown in the image are additional and to be ordered separately.

System	Rope Type	Material of Tensioner	Attachment Ends	Anchorage Type	Max. No. of Users	Max. Span Length	Weight
915132	Kernmantle Rope of dia 16mm	Galvanized Steel	Stiched Loop & Stop Knot	Cross over anchor x2	2 users	5M to 25M	9.02kg

Temporary Horizontal Rope Anchorage Line for 4 Man (Cross Over)

CODE: 915134

AUSSLIFT introduces a new Horizon 4 Man Temporary Horizontal Lifeline made up of Kernmantle Rope of 16mm dia and a uniquely designed Tensioner integrated within the lifeline.

This Lifeline is provided with 4 'Cross Over Anchors' made up of Stainless Steel.



FEATURES:

- Quick & easy to install, and is re-usable
- Suitable for upto 4 personnel
- Highly corrosion resistant Tensioner made of Aluminium & Stainless Steel
- Consists of tension indicator for creating an adequate tension in the Line
- The Lifeline made up of 16mm dia Kernmantle Rope, has a swivel brass connector at one end, which can be connected to a rated anchor point with the help of a Steel Quarter Turn Locking Karabiner 915820. The other end of the lifeline is connected with the help of a Karabiner 915820, connected to the eye of the tensioner. The anchorage line is secured at the termination with the help of a stop-knot covered with a protective sleeve.
- Has Swivel Brass Connector – Specially designed to prevent any twisting of the rope.
- The system has 4 Cross Over Steel Anchors made of Stainless Steel to allow easy crossing over between users, and prevent any disengagement from the lifeline , ensuring 100% tie off at all times
- Total Length of the Line is 25m. Covers a span of 5m to 25m
- Minimum Breaking Strength : 25kN
- The whole system is supplied in a bag , which is permanently attached to the assembly and also enables the user to easily carry the system with the help of comfortable handles provided in the bag. This Bag is designed in such a way that it keeps the unused rope safely, thereby preventing the rope being subjected to abrasion or any damage caused from dust, dirt grime, oil etc.
- Once fitted, you can easily put back the extra rope not deployed along the length, into the Bag.
- Conforms to EN 795:2012 Type C & TS 16415 : 2013 Type C



This temporary horizontal life line comes with a Unique Tension Indicator. Once the required tension is achieved, the disc on the tension indicator gets released indicating the line is ready to use.

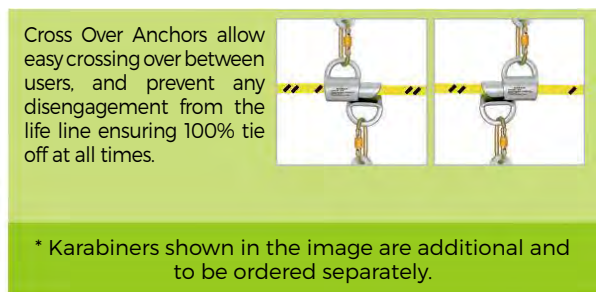

* Karabiners shown in the image are additional and to be ordered separately.

System	Rope Type	Material of Tensioner	Attachment Ends	Anchorage Type	Max. No. of Users	Max. Span Length	Weight
915134	Kernmantle Rope of dia 16mm	Aluminium & Stainless Steel	Swivel brass connector & Stop Knot	Cross over anchor x4	4 users	5M to 25M	10.11kg

Horizontal Anchorage Lifeline System

CODE: 915844

Horizon PN 4000 provides permanent anchorage to a user who has to constantly move along an elevated horizontal track. It comprises of a Stainless Steel Wire Rope (grade 316) of 8mm diameter running all along the horizontal track, and is installed at the ends using special End Extremity Posts. The Intermediate brackets hold the wire in position all along the length of the wire, and are installed at intervals of Maximum 15mtrs. The Wire Rope is maintained in tension with the help of Tensioner at one end, while the other end has a swageless termination on to the Eye of the End Extremity Post.

The Stainless Steel Carriage Body connects the user to the line with the help of a Lanyard and moves smoothly without interruption along the entire length of the Horizontal line and also through the Intermediate Brackets, thus ensuring 100% anchorage of the user at all times.

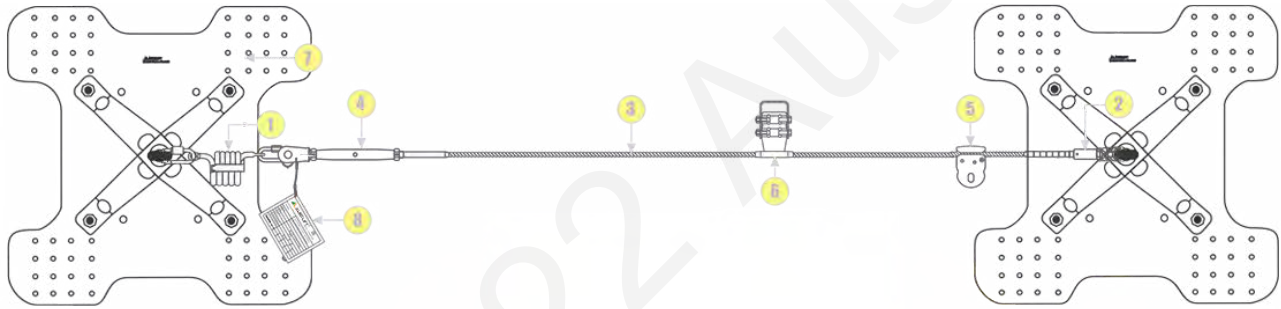
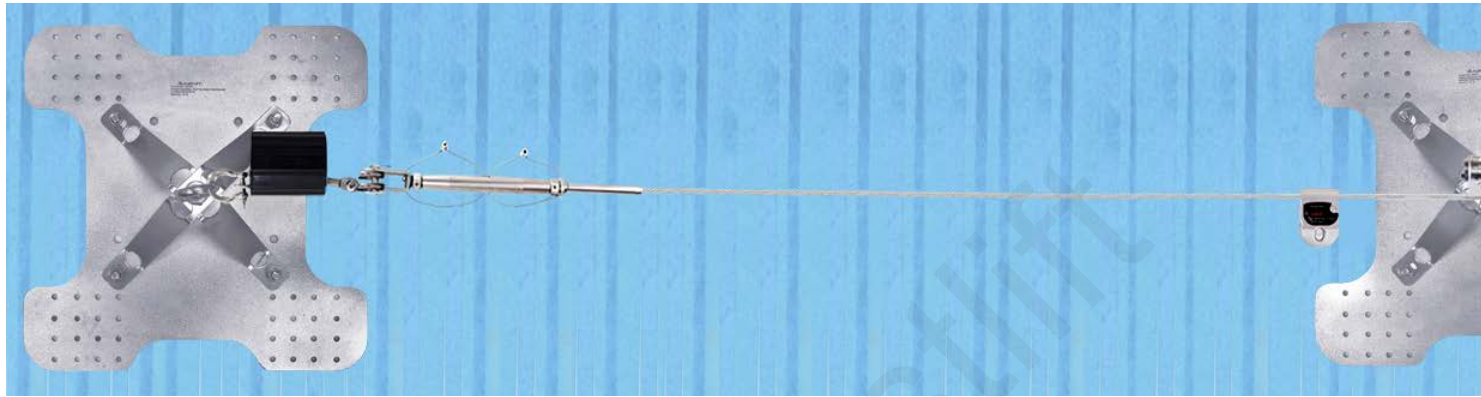

For Trapezoidal Sheet		For Standing Seam Sheet	
Roof Top Anchor Post Extremity	Roof Top Anchor Post Intermediate	Roof Top Anchor Post Extremity	Roof Top Anchor Post Intermediate

Intermediate Brackets Orientation for different Installation		
Ceiling Mounting	Floor Mounting	Wall Mounting

Fall Protection Equipment

CODE: 915844

The line also has a Shock Absorber at one end which reduces the impact of fall both on the user as well as on the extremities. The system also has an Inspection Name Plate for identification, traceability and maintenance of inspection records. One Stainless Steel Cable tie is used to fasten the System Name Plate to the structure. At time of installation, the relevant details are punched on the plate by a number punch. The revalidation dates are punched each year on the plates after inspection and revalidation.

The System is versatile and can be installed on Walls, Floors, Ceilings as well as on Pre-engineered Building Roofs, Fragile Roofs, Airports using the same components by using appropriate posts to install the system to the client's receiving structure.

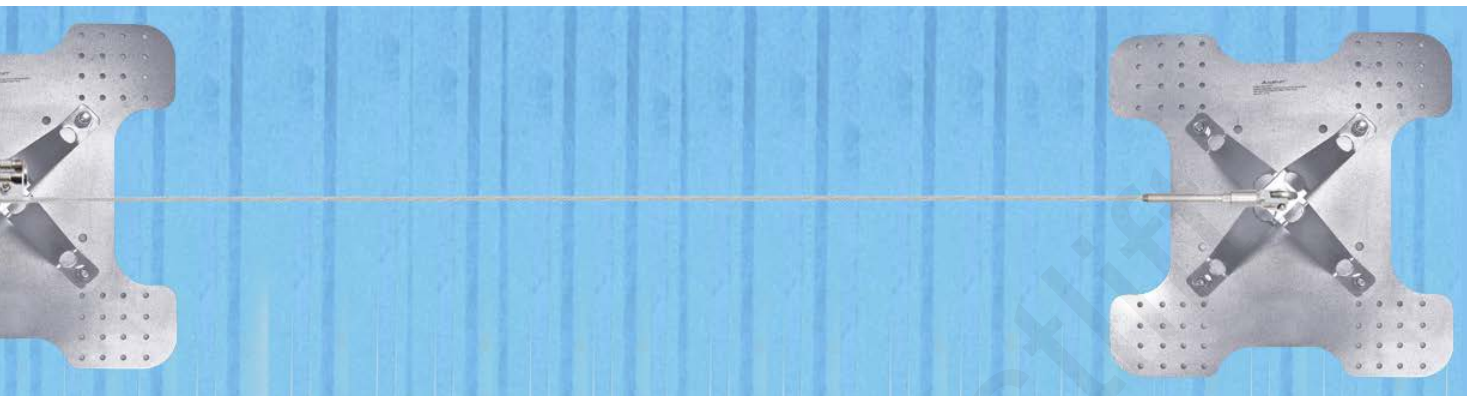

Spring Type Shock Absorber



Cable extremity with swage end assembly

No.	Name	Ref. No	Description
1	Shock Absorber	915879	Material: Stainless Steel 316
2	Swaged Cable Extremity	915899	Allows crimping of the cable wire at the desired length, and eliminates danger of any loose wire. Material: Stainless Steel 316. Feature: Swage Termination
3	Wire Rope	915881	Material: Stainless Steel 316 Diameter: 8mm Construction: 7x19
4	Swaged Tensioner	915891	Regulates tensioning of the cable Material: Stainless Steel 316 Feature: Swage Termination
5	Carriage Body	915883	Material: Stainless Steel 316 Feature: Friction Free Movement
6	Intermediate	915885	Material: Stainless Steel 316. Recommended Installation every 15M (50ft)
7	Roof top anchor post extremity	915877	Material: Stainless Steel 316
8	Inspection Plate	915872	Inspection Plate



Wire Rope



Swaged Tensioner



Carriage Body



Intermediate



Roof top anchor post extremity



Inspection Plate

Fall protection Equipment

Vertical Anchorage Line on Rigid Cable Line

CODE: 915845

Conforming to the Norm EN 353-1:2012 this vertical Fall Arrest system is an integrated solution to arrest the fall of a user who has to constantly climb up & down a ladder:

- The unique feature of this system is a permanent installed Stainless Steel Shock Absorber at the top of the line which offers distinct advantage over the textile absorber used in other lines in term of UV degradation and resistance to harsh climate Conditions. Also the Shock Absorber is constructed of unique design that helps in easy installation of the system.
- The Vertical Anchorage Line is made of Stainless Steel wire rope & is maintained in the rigid position by the use of 2 mounting brackets: one at the top, one at the bottom.
- The Stainless-steel Rope Grab is directly connected to the user without any additional lanyard.
- To maintain the rigidity & high tension in the anchorage line, a screw type mechanical tensioner is provided at the end of the anchorage line at the bottom, connecting it to the lower mounting bracket. The Tensioner is provided with a unique tension indicator which helps ensure appropriate tension is attained, and maintained in the line.
- The system also has an Inspection Name Plate which is installed on the first rung of the ladder for identification, traceability and maintenance of inspection records.



Ref.
915849
Material
Stainless Steel
Finish
Polished
Min. Breaking Strength
23kN
Weight
1.11Kgs ±0.005Kgs
Conforms to
EN 795:2012 Type A

Optional
**EXTREMITY PLATES FOR
TWO LADDER RUNGS**



Ref.
915851
Material
Alloy Steel
Finish
Hot dip Galvanized
Min. Breaking Strength
23kN
Weight
1.11Kgs ±0.005Kgs
Conforms to
EN 795:2012 Type A

Extremity plate used to install a vertical anchor line made of SS wire Rope installed on a ladder with U bolts & nylock nuts. Fixing on two rungs provides better structural strength to the system.

Fall Protection
Equipment

No.	Name of	Ref. No	Description
1	Mounting Bracket	915847	Material: Stainless Steel 316 Breaking Strength > 23 kN Complies with EN 795 Type A
2	Shock Absorber	915859	Material: Stainless Steel 316 Limits the impact of force in the event of fall to less than 6 kN
3	Wire Rope (with one end having a swaged loop)	915855	Material: Stainless Steel 316 Diameter: 8mm Construction: 7x19
4	Rope Grab	915853	Material: Stainless Steel 316; Anti inversion mechanism
5	Intermediate	915857	Material: Stainless Steel 316 Recommended Installation-1 No. at Every 10m
6	Wire Rope Cap	915865	Material: Aluminium Alloy
7	Set of U-Bolts & Thimbles	915863	U-Bolts: Qty- 4 nos. Material: Stainless Steel 316 Thimbles: Qty- 2 nos. Material: Stainless Steel 316
8	Tensioner	915867	Regulates tensioning of the cable Material: Stainless Steel 316

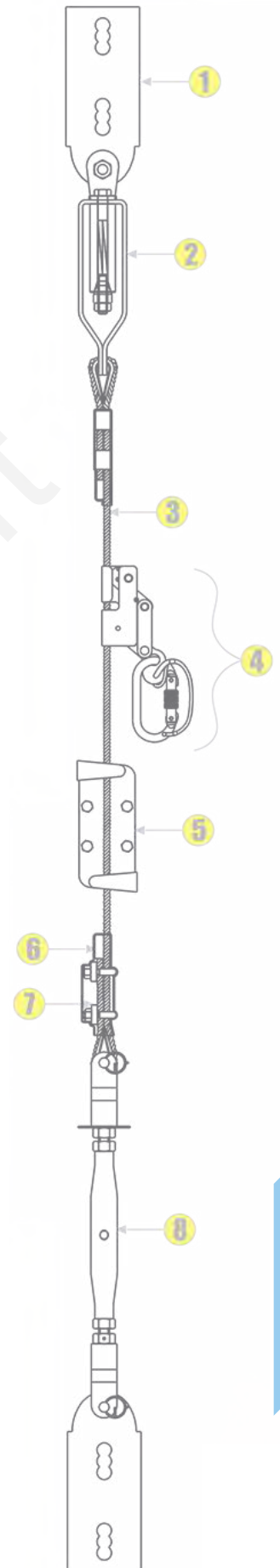

Mounting Bracket



Shock Absorber

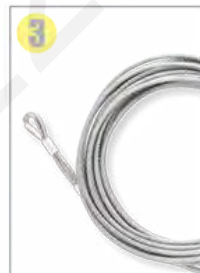

Wire Rope



Rope Grab



Intermediate



Wire Rope Cap



Set of 4 U-bolts and 2 Thimbles



Tensioner

* Also supplied with carbon steel hot dip galvanized mounting brackets to make the system economical.

Fall protection Equipment